

- ① PISTON ROD WIPER
PROLONGS CYLINDER & PISTON ROD LIFE
BY PREVENTING DIRT ENTERING GLAND
- ② GLAND BEARING
PHOSP. BRONZE FOR ADEQUATE LIFE
- ③ GLAND PACKING
SYNTHETIC SINGLE ACTING SEAL
- ④ CYLINDER END CAPS
ACCURATELY MACHINED FROM SOLID STEEL
PROVIDES PRECISE LOCATION FOR BARREL
- ⑤ BARREL / END CAP SEAL
AN O-RING PROVIDES SEALING AT BOTH
ENDS OF BARREL. ANTI EXTRUSION RINGS
FITTED ON SIZES HB60 AND ABOVE
- ⑥ PISTON ROD
MANUFACTURED FROM ALLOY STEEL
HARD CHROME PLATED & POLISHED
- ⑦ BARREL
CYLINDER BARREL MANUFACTURE FROM
SEAMLESS TUBE, HONED & POLISHED
TO GIVE A LONG SEAL LIFE
- ⑧ PISTON
2 PIECE PISTON WITH COMPOSITE SEAL
- ⑨ PISTON PACKING
STANDARD COMPOSITE SEAL WITH SEAR RINGS
- ⑩ PISTON
ALTERNATIVE PISTON, 1 PIECE CAST IRON
WITH SINGLE ACTING "LIP" TYPE SEALS.
- ⑪ TIE RODS
MANUFACTURED FROM HIGH TENSILE ALLOY
STEEL. ON CYLINDERS HB80 & ABOVE, MULTIPLE
TIE RODS ARE USED
- ⑫ CYLINDER PORTS
B.S.P.P. THREADS ARE STANDARD. SPECIAL
PORTS MAY BE SPECIFIED BY CUTOMER

CUSHION ASSEMBLY (IF APPLICABLE)

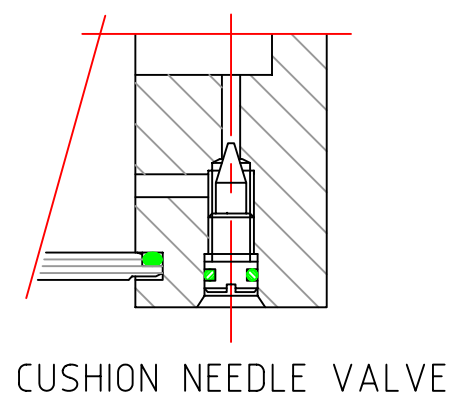

NOMINAL WORKING PRESSURE
3000 P.S.I. (207 Bar.)

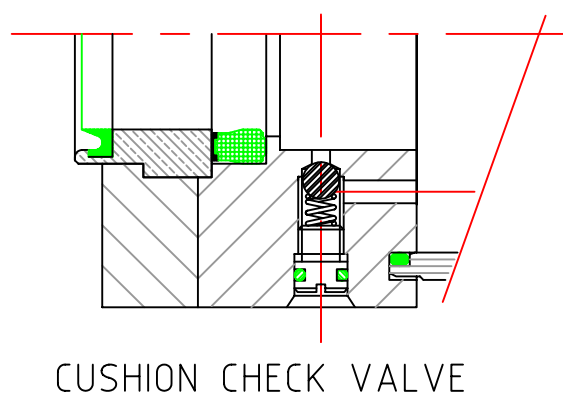
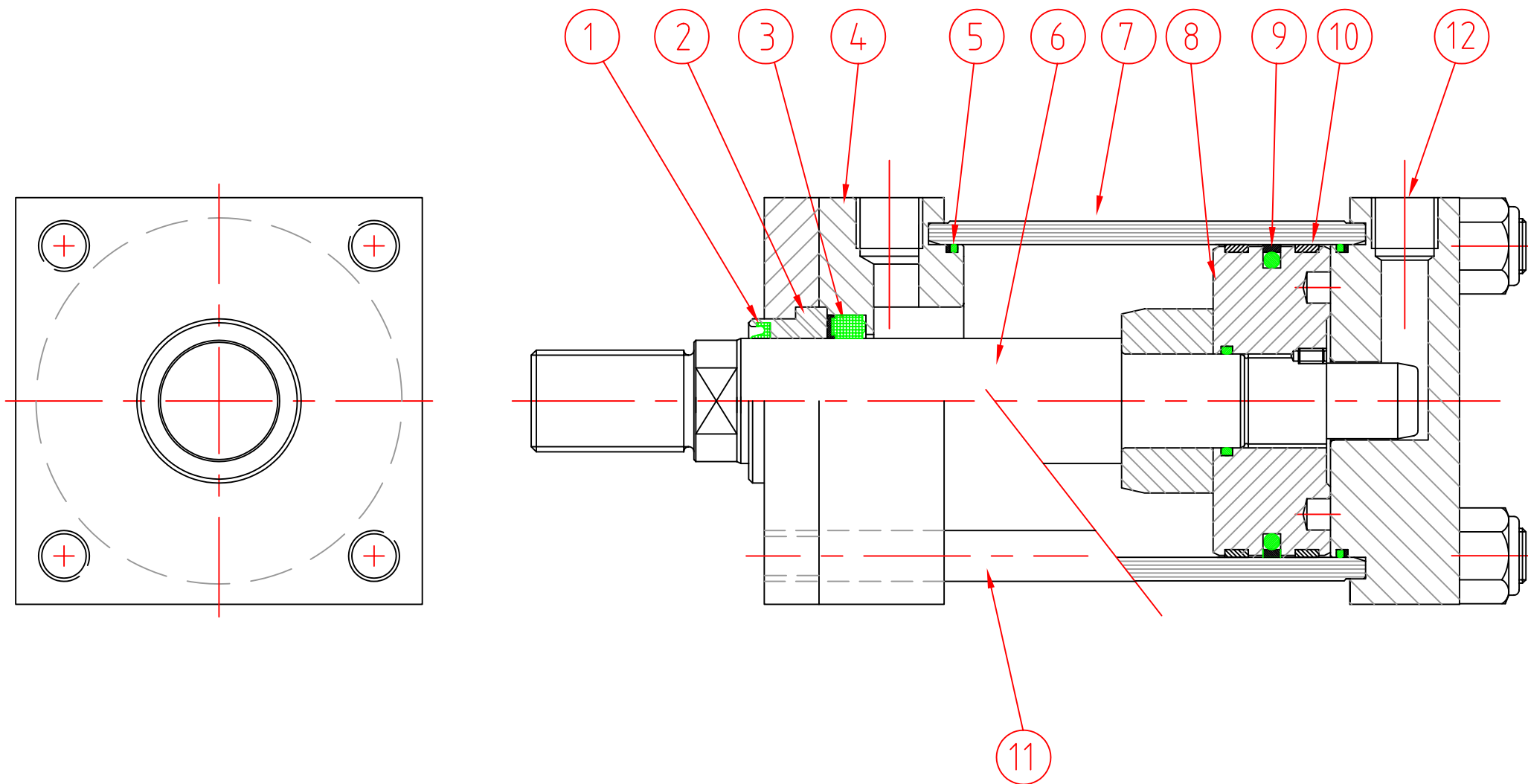

- ① PISTON ROD WIPER
PROLONGS CYLINDER & PISTON ROD LIFE
BY PREVENTING DIRT ENTERING GLAND
- ② GLAND BEARING
PHOSP. BRONZE FOR ADEQUATE LIFE
- ③ GLAND PACKING
SYNTHETIC SINGLE ACTING SEAL
- ④ CYLINDER END CAPS
ACCURATELY MACHINED FROM SOLID STEEL
PROVIDES PRECISE LOCATION FOR BARREL
- ⑤ BARREL / END CAP SEAL
AN O-RING PROVIDES SEALING AT BOTH
ENDS OF BARREL. ANTI EXTRUSION RINGS
FITTED ON SIZES HB50 AND ABOVE
- ⑥ PISTON ROD
MANUFACTURED FROM ALLOY STEEL
HARD CHROME PLATED & POLISHED
- ⑦ BARREL
CYLINDER BARREL MANUFACTURE FROM
SEAMLESS TUBE, HONED & POLISHED
TO GIVE A LONG SEAL LIFE
- ⑧ PISTON
1 PIECE PISTON WITH COMPOSITE SEAL
- ⑨ PISTON PACKING
STANDARD DOUBLE ACTING SEAL
- ⑩ PISTON WEAR RINGS
ALTERNATIVE PISTON, 1 PIECE CAST IRON
WITH SINGLE ACTING "LIP" TYPE SEALS.
- ⑪ TIE RODS
MANUFACTURED FROM HIGH TENSILE ALLOY
STEEL. ON CYLINDERS HB80 & ABOVE, MULTIPLE
TIE RODS ARE USED
- ⑫ CYLINDER PORTS
B.S.P.P. THREADS ARE STANDARD. SPECIAL
PORTS MAY BE SPECIFIED BY CUTOMER

CUSHION ASSEMBLY (IF APPLICABLE)

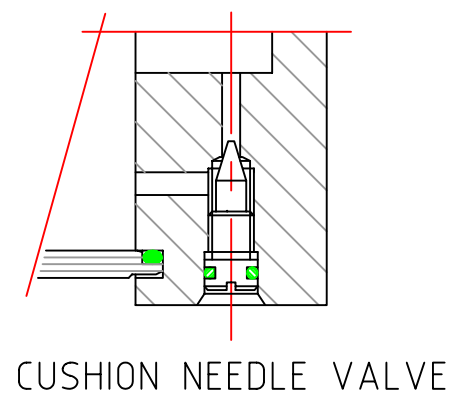
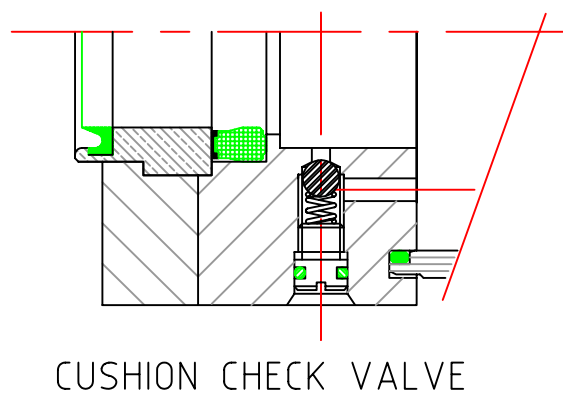

NOMINAL WORKING PRESSURE
3000 P.S.I. (207 Bar.)

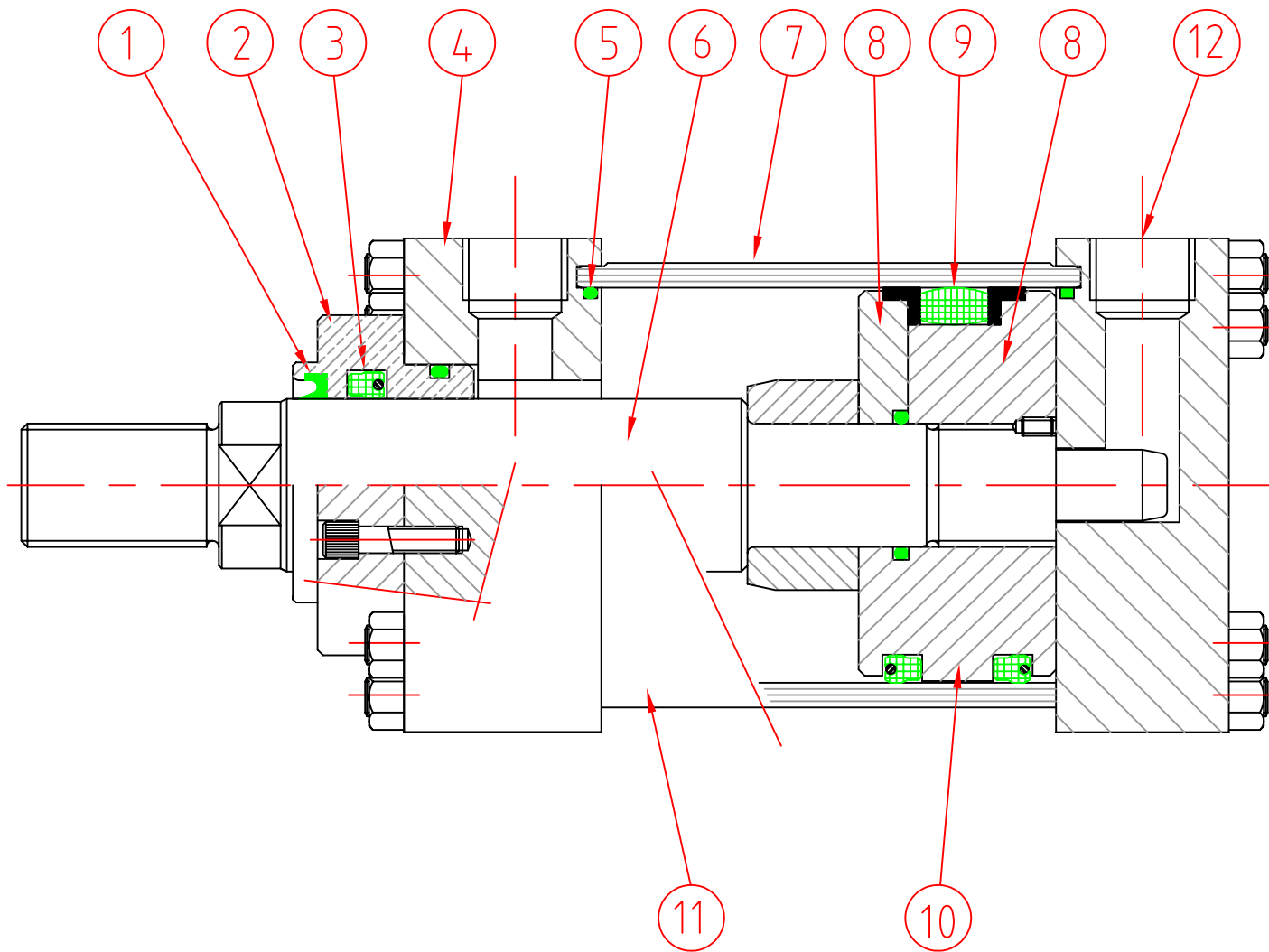
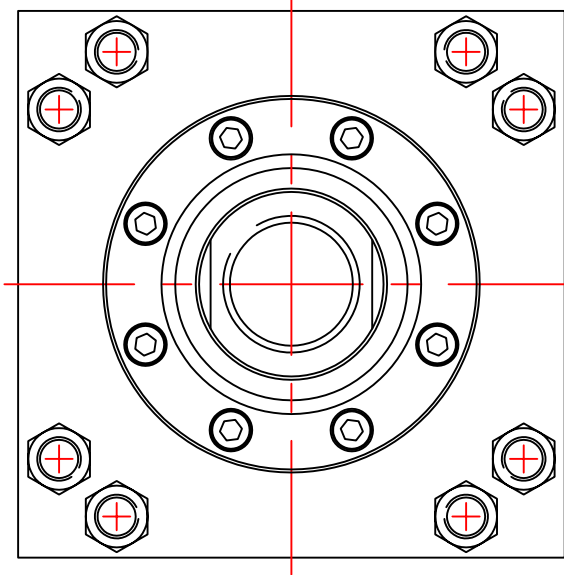

- ① PISTON ROD WIPER
PROLONGS CYLINDER & PISTON ROD LIFE
BY PREVENTING DIRT ENTERING GLAND
- ② GLAND BEARING
PHOSP. BRONZE FOR ADEQUATE LIFE
- ③ GLAND PACKING
SYNTHETIC SINGLE ACTING SEAL
- ④ CYLINDER END CAPS
ACCURATELY MACHINED FROM SOLID STEEL
PROVIDES PRECISE LOCATION FOR BARREL
- ⑤ BARREL / END CAP SEAL
AN O-RING WITH ANTI EXTRUSION RING
PROVIDES SEALING AT BOTH ENDS OF BARREL
- ⑥ PISTON ROD
MANUFACTURED FROM ALLOY STEEL
HARD CHROME PLATED & POLISHED
- ⑦ BARREL
CYLINDER BARREL MANUFACTURE FROM
SEAMLESS TUBE, HONED & POLISHED
TO GIVE A LONG SEAL LIFE
- ⑧ PISTON
2 PIECE PISTON WITH COMPOSITE SEAL
- ⑨ PISTON PACKING
STANDARD COMPOSITE SEAL WITH SEAR RINGS
- ⑩ PISTON
ALTERNATIVE PISTON, 1 PIECE CAST IRON
WITH SINGLE ACTING "LIP" TYPE SEALS.
- ⑪ TIE RODS
MANUFACTURED FROM HIGH TENSILE ALLOY
STEEL
- ⑫ CYLINDER PORTS
B.S.P.P. THREADS ARE STANDARD. SPECIAL
PORTS MAY BE SPECIFIED BY CUTOMER

CUSHION ASSEMBLY (IF APPLICABLE)

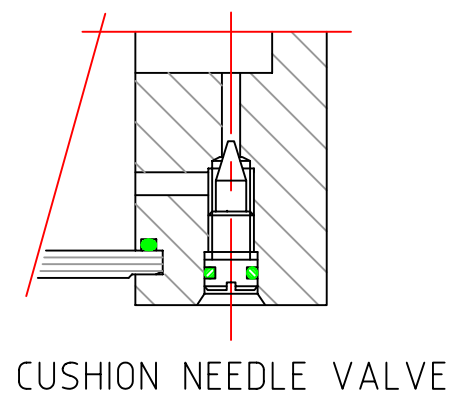
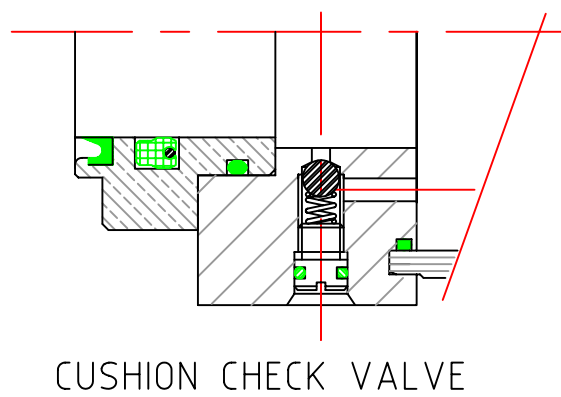

NOMINAL WORKING PRESSURE
3000 P.S.I. (207 Bar.)

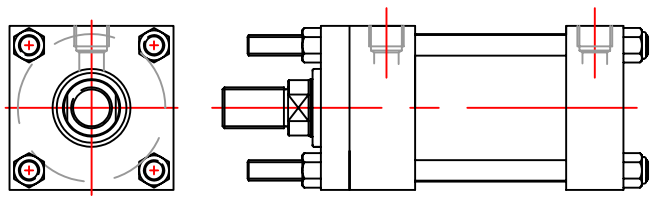

TIE RODS EXTENDED
 STYLE 1 NFPA MX3 HEAD END ONLY
 STYLE 1A NFPA MX2 CAP END ONLY
 STYLE 1B NFPA MX1 BOTH ENDS

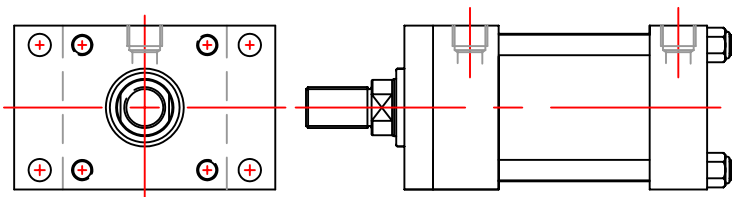

STYLE 2 NFPA MF1
 HEAD RECTANGULAR FLANGE

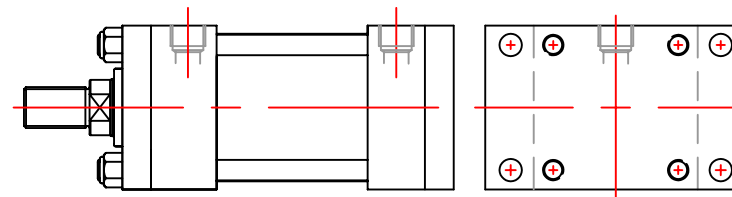

STYLE 3 NFPA MF2
 CAP RECTANGULAR FLANGE

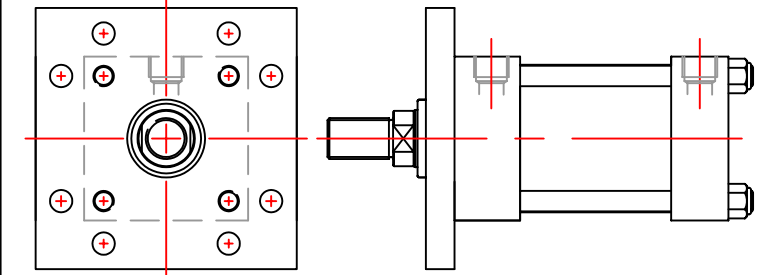

STYLE 4 NFPA MF5
 HEAD SQUARE FLANGE

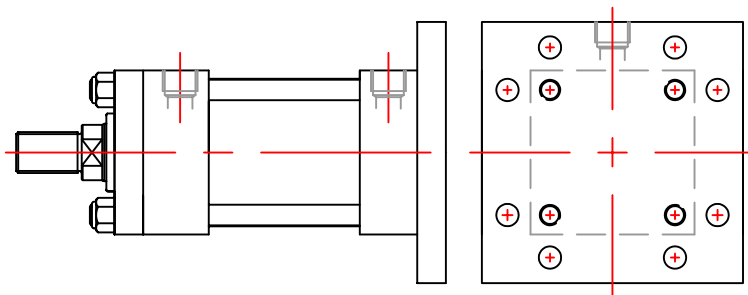

STYLE 5 NFPA MF6
 CAP SQUARE FLANGE

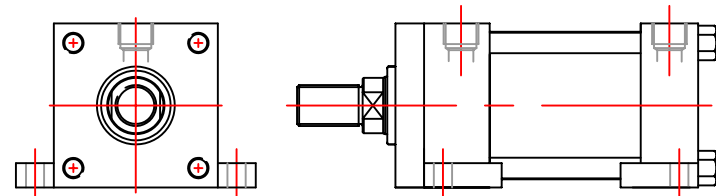

STYLE 6 NFPA MS2
 SIDE LUGS

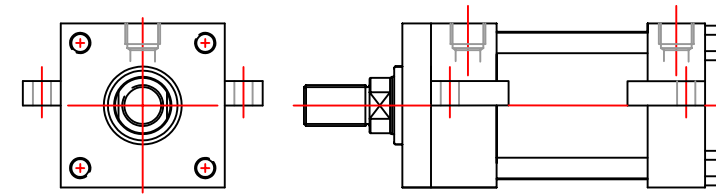

STYLE 7 NFPA MS3
 CENTRE-LINE LUGS

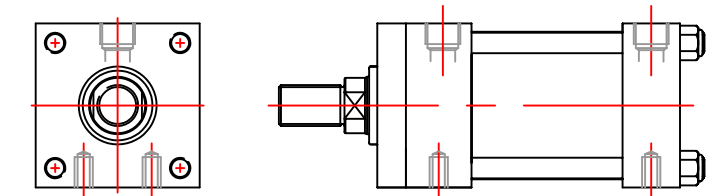

STYLE 8 NFPA MS4
 SIDE TAPPED

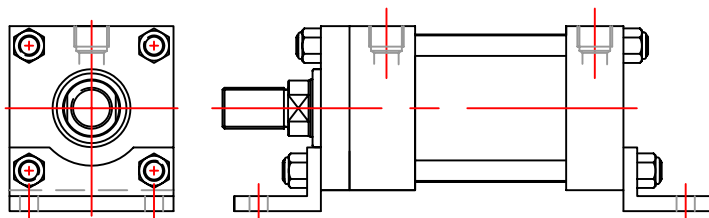

STYLE 9 NFPA MS1
 END ANGLES

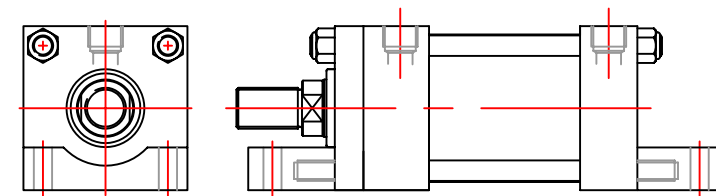

STYLE 10 NFPA MS7
 END LUGS

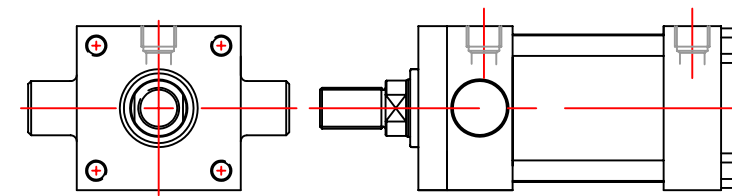

STYLE 11 NFPA MT1
 HEAD TRUNNION

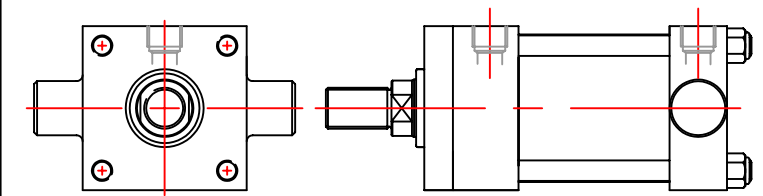

STYLE 12 NFPA MT2
 CAP TRUNNION

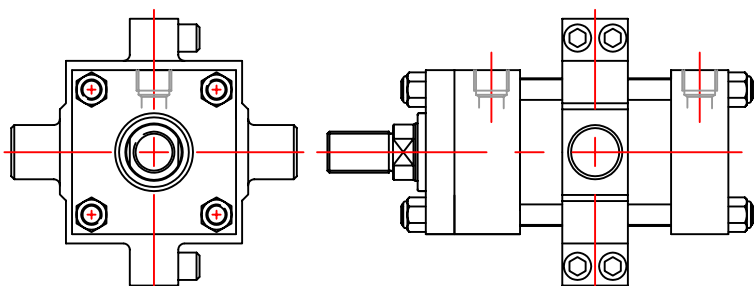

STYLE 13 NFPA MT4
 INTERMEDIATE TRUNNION

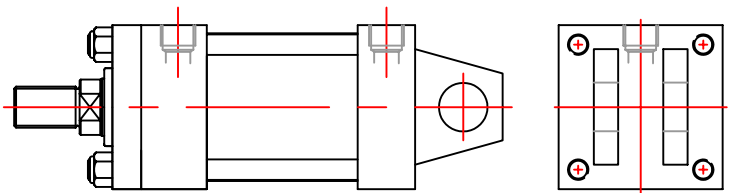

STYLE 14 NFPA MP1
 CAP FIXED CLEVIS

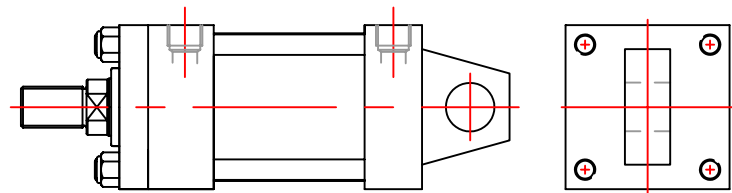

STYLE 14A NFPA MP3
 CAP FIXED EYE

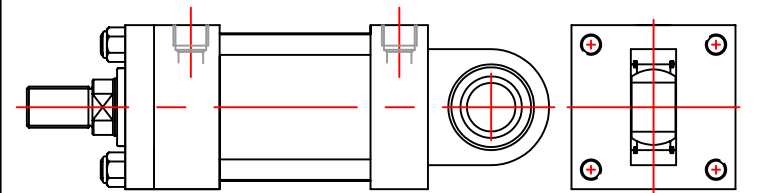

STYLE 14B NFPA MU3
 CAP SPHERICAL BEARING

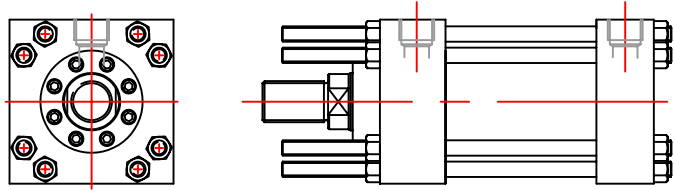

TIE RODS EXTENDED
 STYLE 1 NFPA MX3 HEAD END ONLY
 STYLE 1A NFPA MX2 CAP END ONLY
 STYLE 1B NFPA MX1 BOTH ENDS

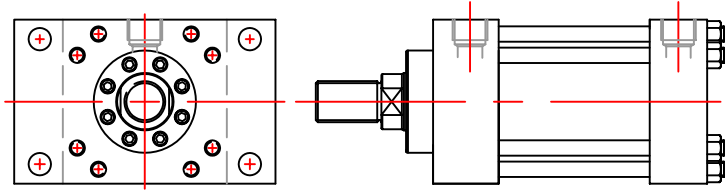

STYLE 2 NFPA MFI
 HEAD RECTANGULAR FLANGE

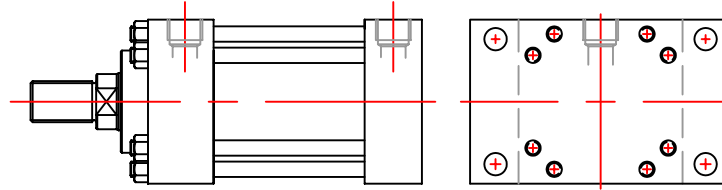

STYLE 3 NFPA MF2
 CAP RECTANGULAR FLANGE

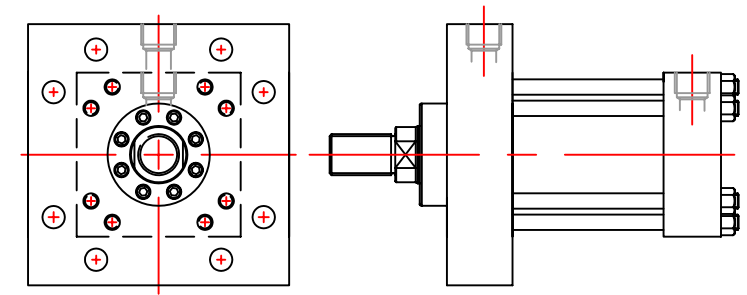

STYLE 4 NFPA MF5
 HEAD SQUARE FLANGE

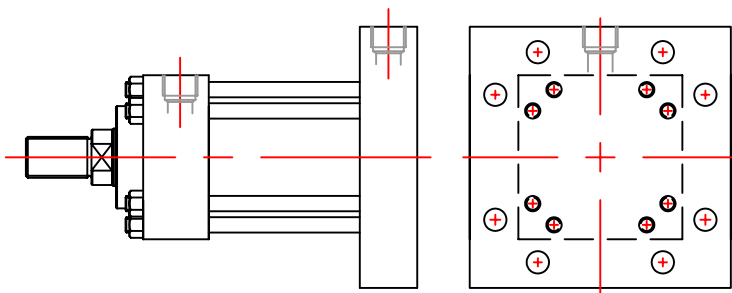

STYLE 5 NFPA MF6
 CAP SQUARE FLANGE

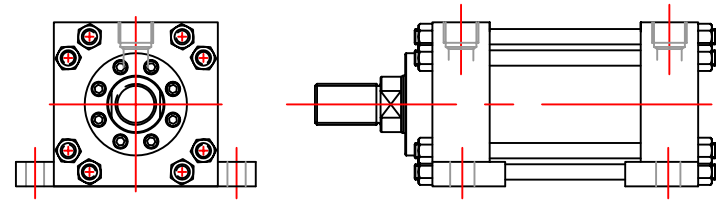

STYLE 6 NFPA MS2
 SIDE LUGS

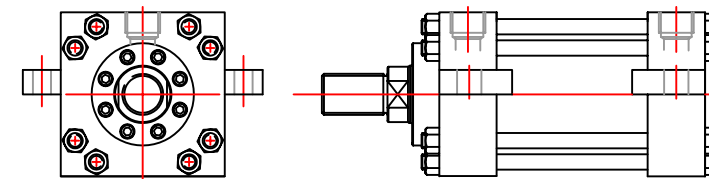

STYLE 7 NFPA MS3
 CENTRE-LINE LUGS

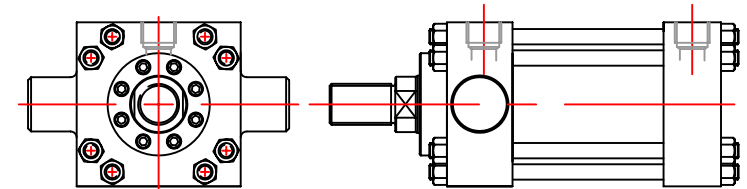

STYLE 11 NFPA MT1
 HEAD TRUNNION

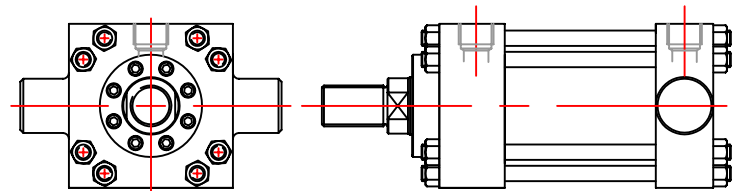

STYLE 12 NFPA MT2
 CAP TRUNNION

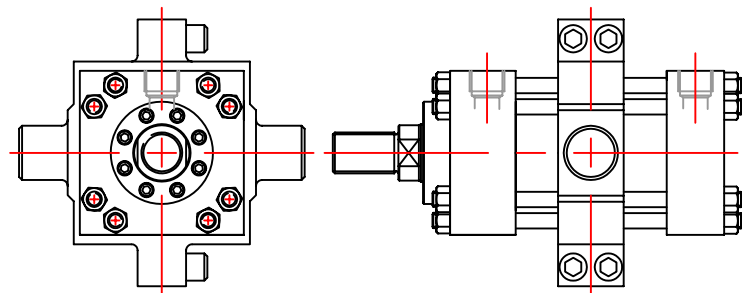

STYLE 13 NFPA MT4
 INTERMEDIATE TRUNNION

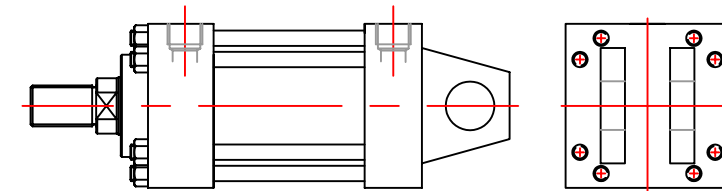

STYLE 14 NFPA MP1
 CAP FIXED CLEVIS

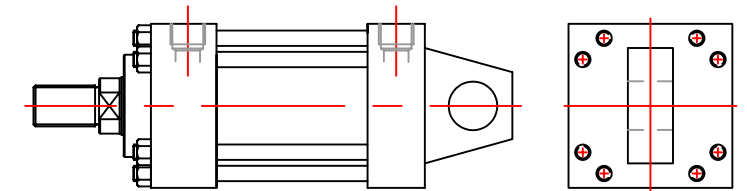

STYLE 14A NFPA MP3
 CAP FIXED EYE

ORDERING HB SERIES HYDRAULIC CYLINDERS

HB - 25 - 14 - 10.00" - A - 1 - NC - 1 - RC100 - CP100 - S

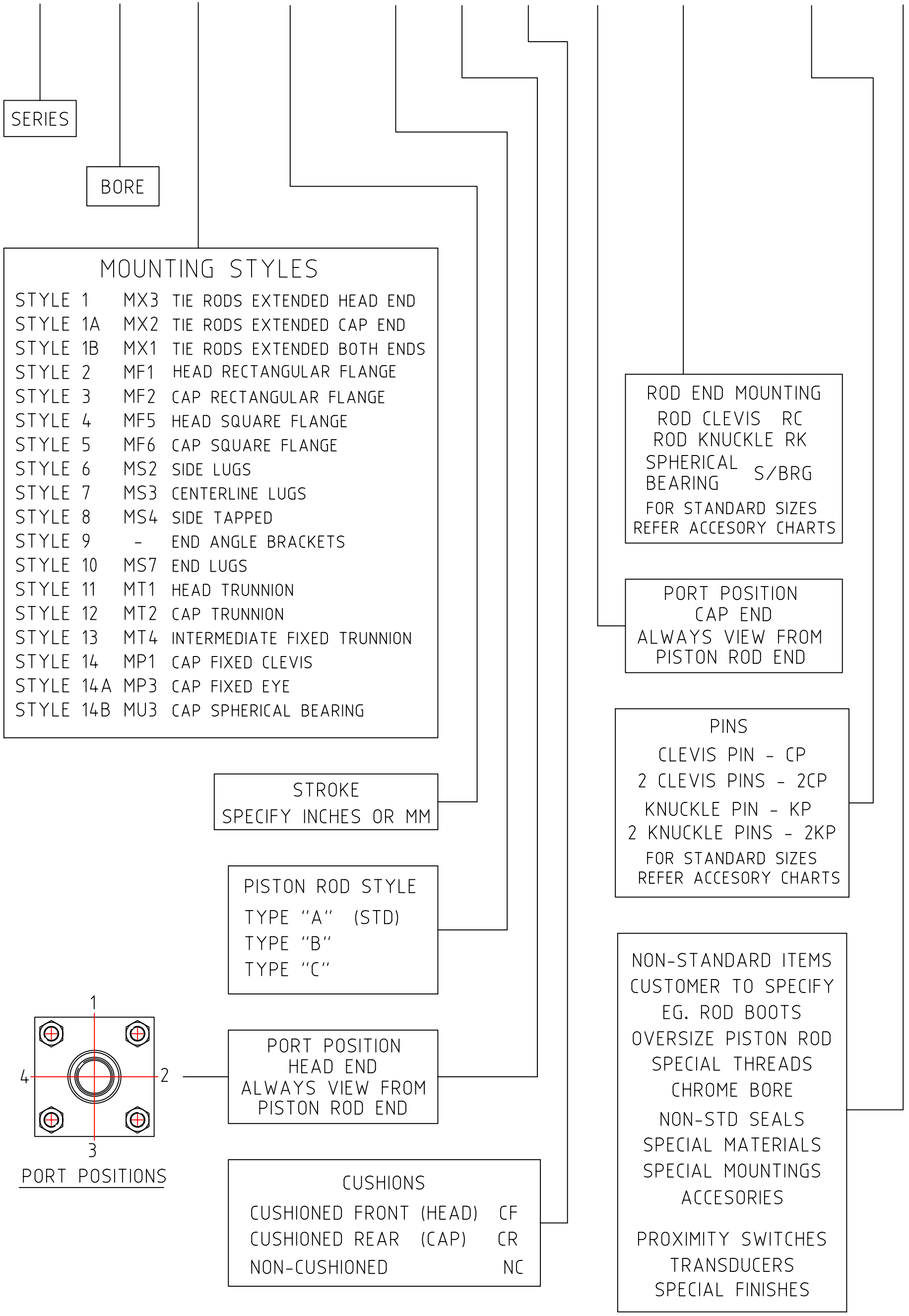

SERIES

BORE

MOUNTING STYLES

STYLE 1	MX3	TIE RODS EXTENDED HEAD END
STYLE 1A	MX2	TIE RODS EXTENDED CAP END
STYLE 1B	MX1	TIE RODS EXTENDED BOTH ENDS
STYLE 2	MF1	HEAD RECTANGULAR FLANGE
STYLE 3	MF2	CAP RECTANGULAR FLANGE
STYLE 4	MF5	HEAD SQUARE FLANGE
STYLE 5	MF6	CAP SQUARE FLANGE
STYLE 6	MS2	SIDE LUGS
STYLE 7	MS3	CENTERLINE LUGS
STYLE 8	MS4	SIDE TAPPED
STYLE 9	-	END ANGLE BRACKETS
STYLE 10	MS7	END LUGS
STYLE 11	MT1	HEAD TRUNNION
STYLE 12	MT2	CAP TRUNNION
STYLE 13	MT4	INTERMEDIATE FIXED TRUNNION
STYLE 14	MP1	CAP FIXED CLEVIS
STYLE 14A	MP3	CAP FIXED EYE
STYLE 14B	MU3	CAP SPHERICAL BEARING

STROKE
SPECIFY INCHES OR MM

PISTON ROD STYLE
TYPE "A" (STD)
TYPE "B"
TYPE "C"

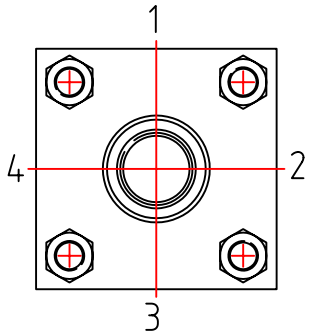

PORT POSITIONS

PORT POSITION
HEAD END
ALWAYS VIEW FROM
PISTON ROD END

CUSHIONS
CUSHIONED FRONT (HEAD) CF
CUSHIONED REAR (CAP) CR
NON-CUSHIONED NC

ROD END MOUNTING
ROD CLEVIS RC
ROD KNUCKLE RK
SPHERICAL S/BRG
BEARING
FOR STANDARD SIZES
REFER ACCESSORY CHARTS

PORT POSITION
CAP END
ALWAYS VIEW FROM
PISTON ROD END

PINS
CLEVIS PIN - CP
2 CLEVIS PINS - 2CP
KNUCKLE PIN - KP
2 KNUCKLE PINS - 2KP
FOR STANDARD SIZES
REFER ACCESSORY CHARTS

NON-STANDARD ITEMS
CUSTOMER TO SPECIFY
EG. ROD BOOTS
OVERSIZE PISTON ROD
SPECIAL THREADS
CHROME BORE
NON-STD SEALS
SPECIAL MATERIALS
SPECIAL MOUNTINGS
ACCESSORIES
PROXIMITY SWITCHES
TRANSDUCERS
SPECIAL FINISHES

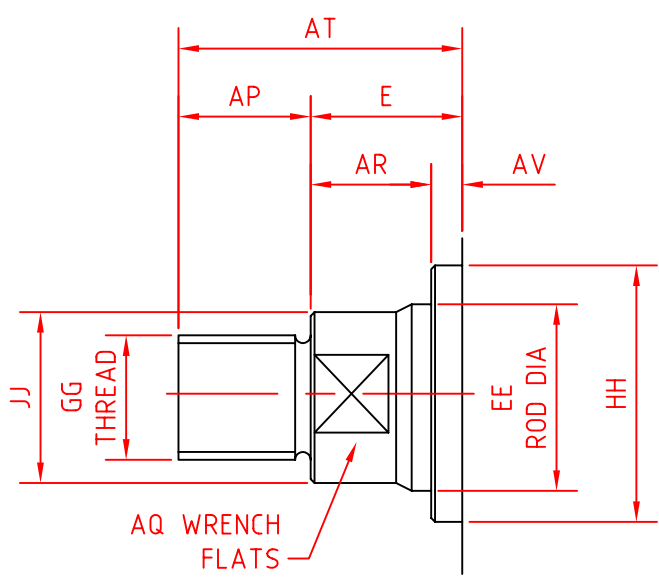

TYPE "A"

SUPPLIED AS STANDARD
IF ROD END NOT SPECIFIED

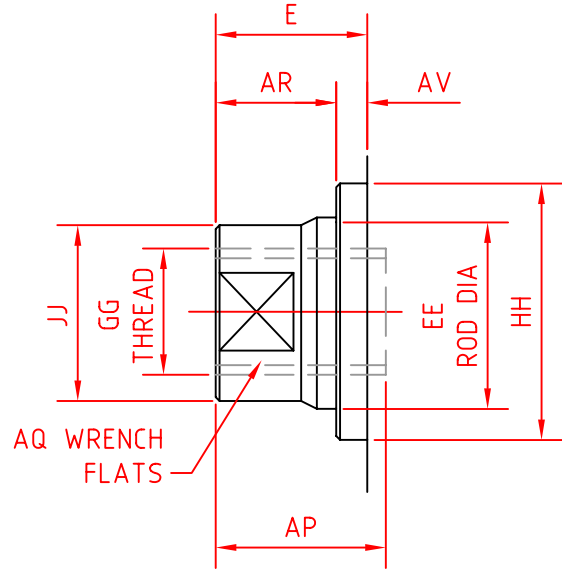

TYPE "B"

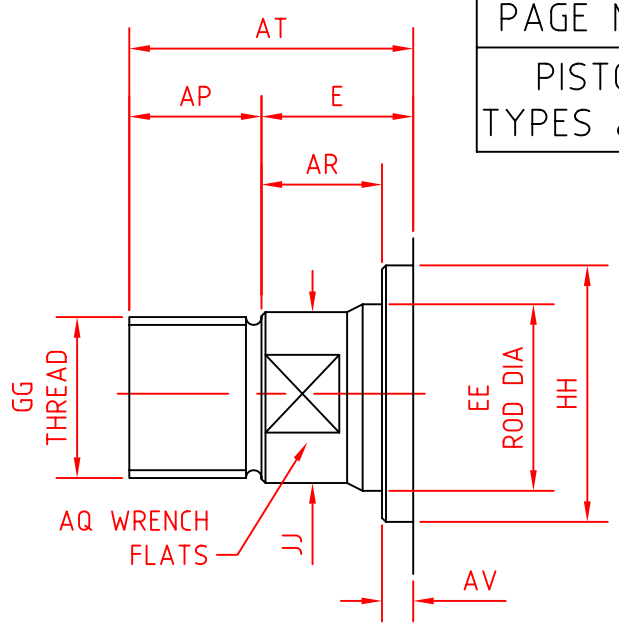

TYPE "C"

NOTE. TO USE GLAND HH AS LOCATION
USE BS1916 H8 FIT FOR HOLE

CYLINDER SIZE	ROD DIA EE	FF	GG	AP	HH	AR	AQ	AT	JJ	AV	E
HB 15 1.500" BORE	0.625" STD 15.87	1/2"-20	7/16"-20	0.75" 19.05	1.13" 28.57	0.38" 9.52	0.50" 12.70	1.38" 34.92	0.56" 14.28	0.25" 6.35	0.63" 15.87
	1.000" 25.40	7/8"-14	3/4"-16	1.13" 28.57	1.50" 38.10	0.50" 12.70	0.88" 22.22	2.13" 54.37	0.94" 23.81	0.50" 12.70	1.00" 25.40
HB 20 2.000" BORE	1.000" STD 25.40	7/8"-14	3/4"-16	1.13" 28.57	1.50" 38.10	0.50" 12.70	0.88" 22.22	1.88" 47.62	0.94" 23.81	0.25" 6.35	0.75" 19.05
	1.375" 34.92	1.1/4"-12	1"-14	1.63" 41.27	2.00" 50.80	0.63" 15.87	1.13" 28.57	2.63" 66.67	1.31" 33.33	0.38" 9.52	1.00" 25.40
HB 25 2.500" BORE	1.000" STD 25.40	7/8"-14	3/4"-16	1.13" 28.57	1.50" 38.10	0.50" 12.70	0.88" 22.22	1.88" 47.62	0.94" 23.81	0.25" 6.35	0.75" 19.05
	1.375" 34.92	1.1/4"-12	1"-14	1.63" 41.27	2.00" 50.80	0.63" 15.87	1.13" 28.57	2.63" 66.67	1.31" 33.33	0.38" 9.52	1.00" 25.40
	1.750" 44.45	1.1/2"-12	1.1/4"-12	2.00" 50.80	2.38" 60.32	0.75" 19.05	1.50" 38.10	3.25" 82.55	1.69" 42.86	0.50" 12.70	1.25" 31.75
HB 32 3.250" BORE	1.375" STD 34.92	1.1/4"-12	1"-14	1.63" 41.27	2.00" 50.80	0.63" 15.87	1.13" 28.57	2.50" 63.50	1.31" 33.33	0.25" 6.35	0.88" 22.22
	1.750" 44.45	1.1/2"-12	1.1/4"-12	2.00" 50.80	2.38" 60.32	0.75" 19.05	1.50" 38.10	3.13" 79.37	1.69" 42.86	0.38" 9.52	1.13" 28.57
	2.000" 50.80	1.3/4"-12	1.1/2"-12	2.25" 57.15	2.63" 66.67	0.88" 22.22	1.69" 42.86	3.50" 88.90	1.94" 49.21	0.38" 9.52	1.25" 31.75
HB 40 4.000" BORE	1.750" STD 44.45	1.1/2"-12	1.1/4"-12	2.00" 50.80	2.38" 60.32	0.75" 19.05	1.50" 38.10	3.00" 76.20	1.69" 42.86	0.25" 6.35	1.00" 25.40
	2.000" 50.80	1.3/4"-12	1.1/2"-12	2.25" 57.15	2.63" 66.67	0.88" 22.22	1.69" 42.86	3.38" 85.72	1.94" 49.21	0.25" 6.35	1.13" 28.57
	2.500" 63.50	2.1/4"-12	1.7/8"-12	3.00" 76.20	3.13" 79.37	1.00" 25.40	2.06" 52.32	4.38" 111.12	2.38" 60.32	0.38" 9.52	1.38" 34.92
HB 50 5.000" BORE	2.000" STD 50.80	1.3/4"-12	1.1/2"-12	2.25" 57.15	2.63" 66.67	0.88" 22.22	1.69" 42.86	3.38" 85.72	1.94" 49.21	0.25" 6.35	1.13" 28.57
	2.500" 63.50	2.1/4"-12	1.7/8"-12	3.00" 76.20	3.13" 79.37	1.00" 25.40	2.06" 52.32	4.38" 111.12	2.38" 60.32	0.38" 9.52	1.38" 34.92
	3.000" 76.20	2.3/4"-12	2.1/4"-12	3.50" 88.90	3.75" 95.25	1.00" 25.40	2.63" 66.67	4.88" 123.82	2.88" 73.02	0.38" 9.52	1.38" 34.92
	3.500" 88.90	3.1/4"-12	2.1/2"-12	3.50" 88.90	4.25" 107.95	1.00" 25.40	3.00" 76.20	4.88" 123.82	3.38" 85.72	0.38" 9.52	1.38" 34.92
HB 60 6.000" BORE	2.500" STD 63.50	2.1/4"-12	1.7/8"-12	3.00" 76.20	3.13" 79.37	1.00" 25.40	2.06" 52.32	4.25" 107.95	2.38" 60.32	0.25" 6.35	1.25" 31.75
	3.000" 76.20	2.3/4"-12	2.1/4"-12	3.50" 88.90	3.75" 95.25	1.00" 25.40	2.63" 66.67	4.75" 120.65	2.88" 73.02	0.25" 6.35	1.25" 31.75
	3.500" 88.90	3.1/4"-12	2.1/2"-12	3.50" 88.90	4.25" 107.95	1.00" 25.40	3.00" 76.20	4.75" 120.65	3.38" 85.72	0.25" 6.35	1.25" 31.75
	4.000" 101.60	3.3/4"-12	3"-12	4.00" 101.60	4.75" 120.65	1.00" 25.40	3.38" 85.72	5.25" 133.35	3.88" 98.42	0.25" 6.35	1.25" 31.75
HB 70 7.000" BORE	3.000" STD 76.20	2.3/4"-12	2.1/4"-12	3.50" 88.90	3.75" 95.25	1.00" 25.40	2.63" 66.67	4.75" 120.65	2.88" 73.02	0.25" 6.35	1.25" 31.75
	3.500" 88.90	3.1/4"-12	2.1/2"-12	3.50" 88.90	4.25" 107.95	1.00" 25.40	3.00" 76.20	4.75" 120.65	3.38" 85.72	0.25" 6.35	1.25" 31.75
	4.000" 101.60	3.3/4"-12	3"-12	4.00" 101.60	4.75" 120.65	1.00" 25.40	3.38" 85.72	5.25" 133.35	3.88" 98.42	0.25" 6.35	1.25" 31.75
	5.000" 127.00	4.3/4"-12	3.1/2"-12	5.00" 127.00	5.75" 146.05	1.00" 25.40	4.25" 107.95	6.25" 158.75	4.88" 123.82	0.25" 6.35	1.25" 31.75
HB 80 8.000" BORE	3.500" STD 88.90	3.1/4"-12	2.1/2"-12	3.50" 88.90	4.25" 107.95	1.00" 25.40	3.00" 76.20	4.75" 120.65	3.38" 85.72	0.25" 6.35	1.25" 31.75
	4.000" 101.60	3.3/4"-12	3"-12	4.00" 101.60	4.75" 120.65	1.00" 25.40	3.38" 85.72	5.25" 133.35	3.88" 98.42	0.25" 6.35	1.25" 31.75
	5.000" 127.00	4.3/4"-12	3.1/2"-12	5.00" 127.00	5.75" 146.05	1.00" 25.40	4.25" 107.95	6.25" 158.75	4.88" 123.82	0.25" 6.35	1.25" 31.75
	5.500" 139.70	5.1/4"-12	4"-12	5.50" 139.70	6.25" 158.75	1.00" 25.40	4.63" 117.60	6.75" 171.45	5.38" 136.52	0.25" 6.35	1.25" 31.75

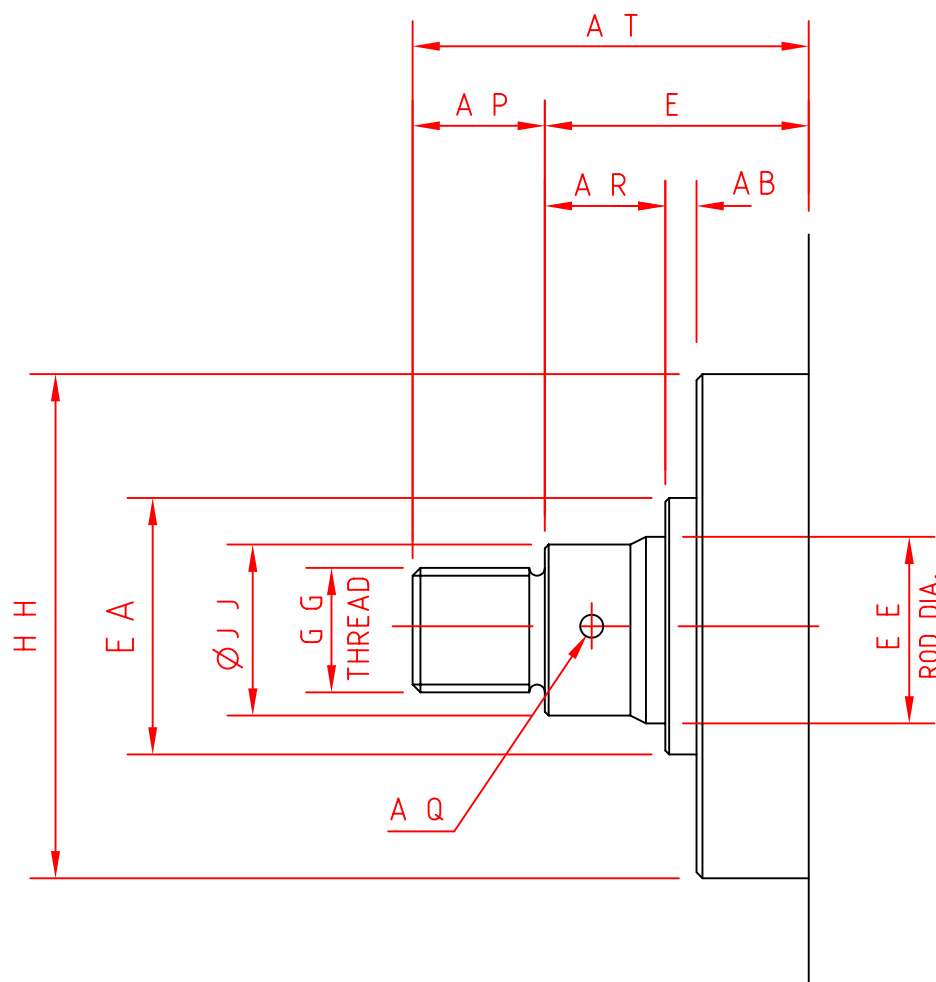

TYPE "A"

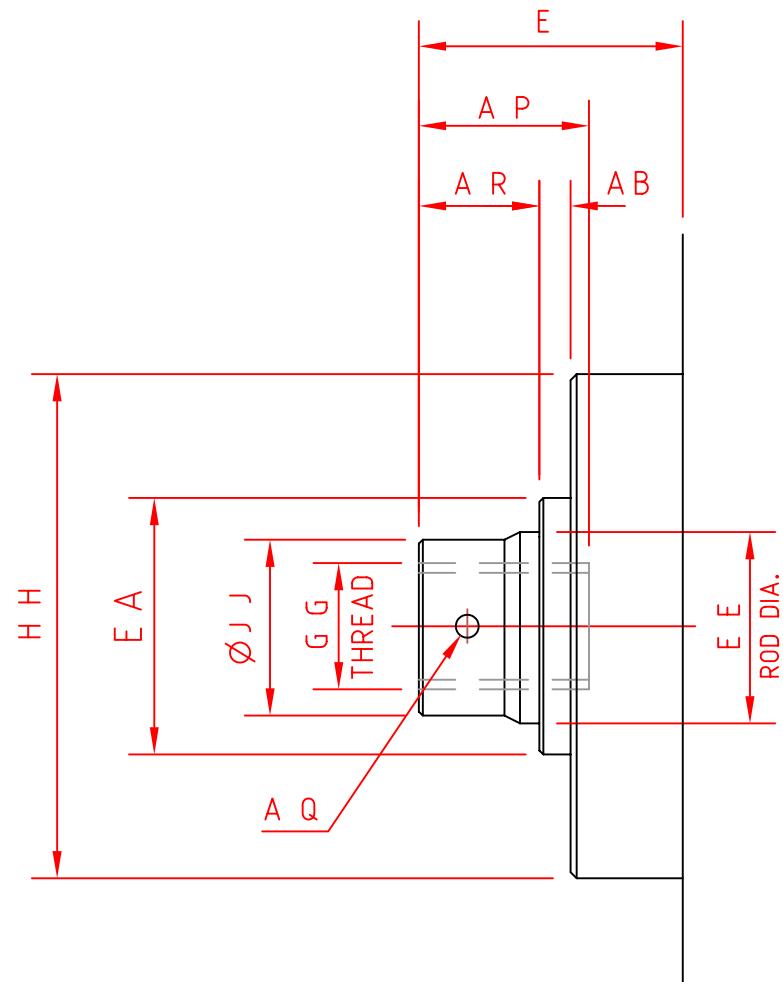

TYPE "B"

(supplied as standard
if rod end not specified.)

CYLINDER SIZE	ROD DIA. E E	G G	E	A P	A R	A T	A B	E A	H H	J J	A Q
HB 100 10.00" BORE	4.500" 114.3	3,1/4"-12	2.94" 74.6	4.50" 114.3	1.00" 25.4	7.44" 188.9	0.44" 11.10	5.75" 146.05	8.25" 209.55	4.38" 111.12	Ø 0.50" x 0.38"Dp.
	5.000" STD. 127.0	3,1/2"-12	3.19" 80.95	5.00" 127.0	1.25" 31.75	8.19" 207.9	0.44" 11.10	6.25" 158.75	8.75" 222.25	4.88" 123.82	Ø 0.50" x 0.50"Dp.
	5.500" 139.7	4.00"-12	3.19" 80.95	5.50" 139.7	1.25" 31.75	8.69" 220.66	0.44" 11.10	7.50" 190.50	9.38" 238.12	5.38" 136.52	
	7.000" 177.8	5.00"-12	3.50" 88.9	7.00" 177.8	1.56" 39.68	10.5" 266.7	0.44" 11.10	8.25" 209.55	10.50" 266.70	6.88" 174.62	
HB 120 12.00" BORE	5.500" 139.7	4.00"-12	3.19" 80.95	5.50" 139.7	1.25" 31.75	8.69" 220.66	0.56" 14.22	7.13" 180.97	9.38" 238.12	5.38" 136.52	Ø 0.50" x 0.50"Dp.
	7.000" STD. 177.8	5.00"-12	3.50" 88.9	7.00" 177.8	1.56" 39.68	10.5" 266.7	0.56" 14.22	8.75" 222.25	11.00" 279.40	6.88" 174.62	
	8.000" 203.2	5,3/4"-12	4.00" 101.6	8.00" 203.2	2.06" 52.38	12.0" 304.8	0.38" 9.52	10.00" 254.00	12.50" 317.50	7.88" 200.02	Ø 0.50" x 0.63"Dp.

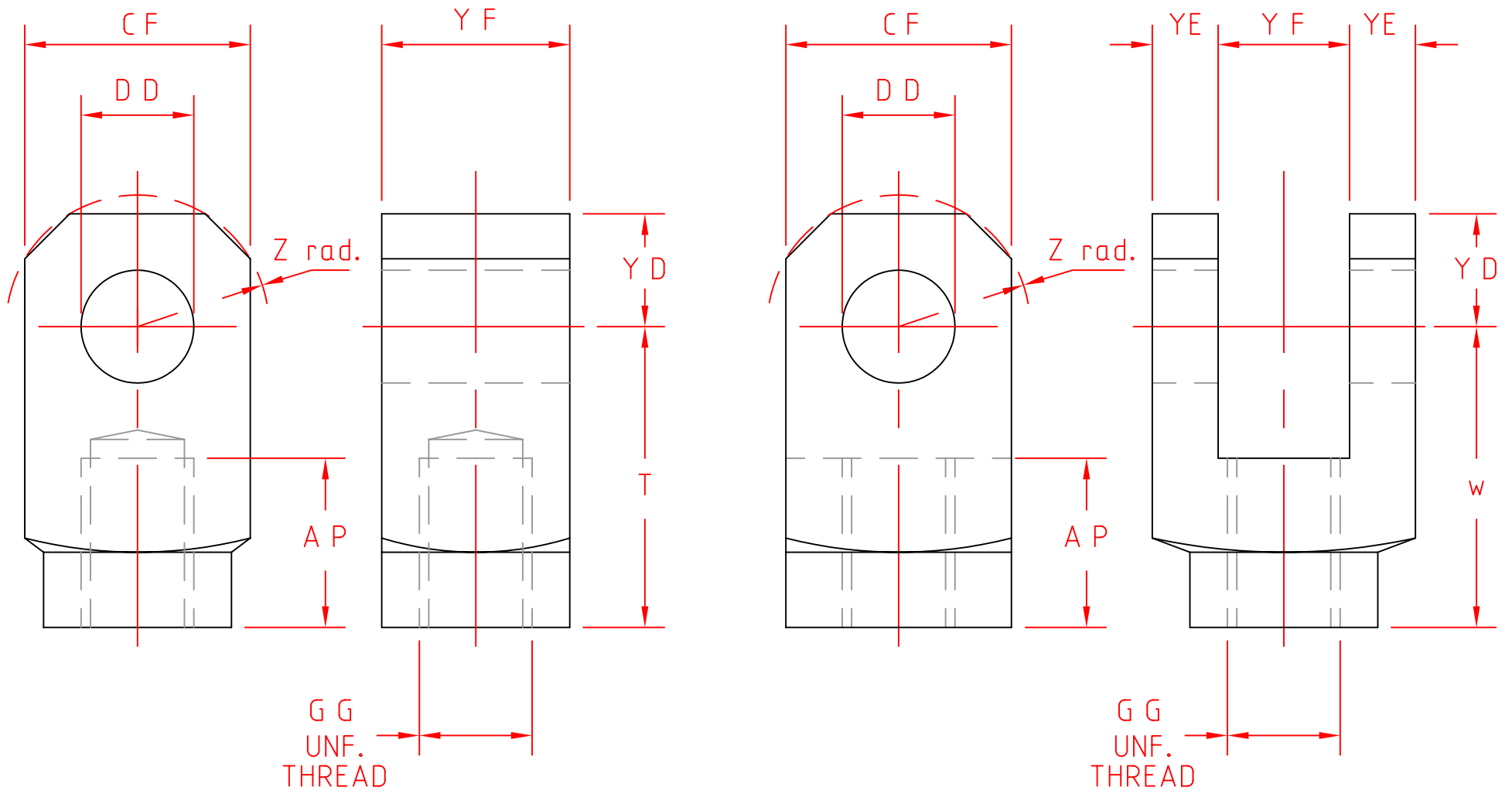

ROD KNUCKLE (RK)

For hole DD use B.S.1916 H8 fit.

ROD CLEVIS (RC)

For hole DD use B.S.1916 H8 fit.

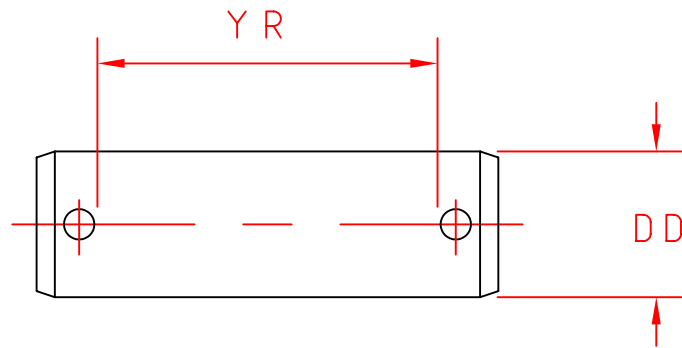

CLEVIS PIN (CP)

For pin use B.S.1916 f8 fit.

NOTE

When ORDERING ACCESSORIES please relate appropriate abbreviation followed by part number.

e.g. ROD KNUCKLE for 1.00" dia. rod.
please quote RK100

PART No.	ROD Dia.EE	THREAD G G	D D	Y R	Y D	T	A P	W	Z RAD	C F	Y E	Y F	PART No.
50	0.500" 12.7	5/16"-24	0.44" 11.11	0.88" 22.22	0.44" 11.11	1.50" 38.1	0.63" 15.87	1.25" 31.75	0.44" 11.11	0.88" 22.22	0.22" 5.6	0.44" 11.11	50
63	0.625" 15.87	7/16"-20	0.50" 12.70	1.75" 44.45	0.50" 12.70	1.50" 38.1	0.75" 19.05	1.50" 38.1	0.63" 15.87	1.00" 25.4	0.50" 12.70	0.75" 19.05	63
100	1.000" 25.4	3/4"-16	0.75" 19.05	2.50" 63.5	0.75" 19.05	2.07" 52.45	1.13" 28.57	2.13" 53.97	0.88" 22.22	1.50" 38.1	0.63" 15.87	1.25" 31.75	100
138	1.375" 34.92	1.00"-14	1.00" 25.4	3.00" 76.2	1.00" 25.4	2.81" 71.4	1.63" 41.27	3.00" 76.2	1.18" 29.9	2.00" 50.8	0.75" 19.05	1.50" 38.1	138
175	1.750" 44.45	1,1/4"-12	1.38" 34.92	4.00" 101.6	1.38" 34.92	3.44" 87.31	2.00" 50.8	3.75" 95.25	1.63" 41.27	2.75" 69.85	1.00" 25.4	2.00" 50.8	175
200	2.000" 50.8	1,1/2"-12	1.75" 44.45	5.00" 127	1.75" 44.45	4.00" 101.6	2.25" 57.15	4.50" 114.3	2.13" 53.97	3.50" 88.9	1.25" 31.75	2.50" 63.5	200
250	2.500" 63.5	1,7/8"-12	2.00" 50.8	5.00" 127	2.00" 50.8	5.00" 127	3.00" 76.2	5.50" 139.7	2.38" 60.32	4.00" 101.6	1.25" 31.75	2.50" 63.5	250
300	3.000" 76.2	2,1/4"-12	2.50" 63.5	6.00" 152.4	2.50" 63.5	5.81" 147.6	3.50" 88.9	6.50" 165.1	2.75" 69.85	5.00" 127	1.50" 38.1	3.00" 76.2	300
350	3.500" 88.9	2,1/2"-12	3.00" 76.2	6.00" 152.4	3.00" 76.2	6.13" 155.57	3.50" 88.9	6.75" 171.45	3.00" 76.2	6.00" 152.4	1.50" 38.1	3.00" 76.2	350

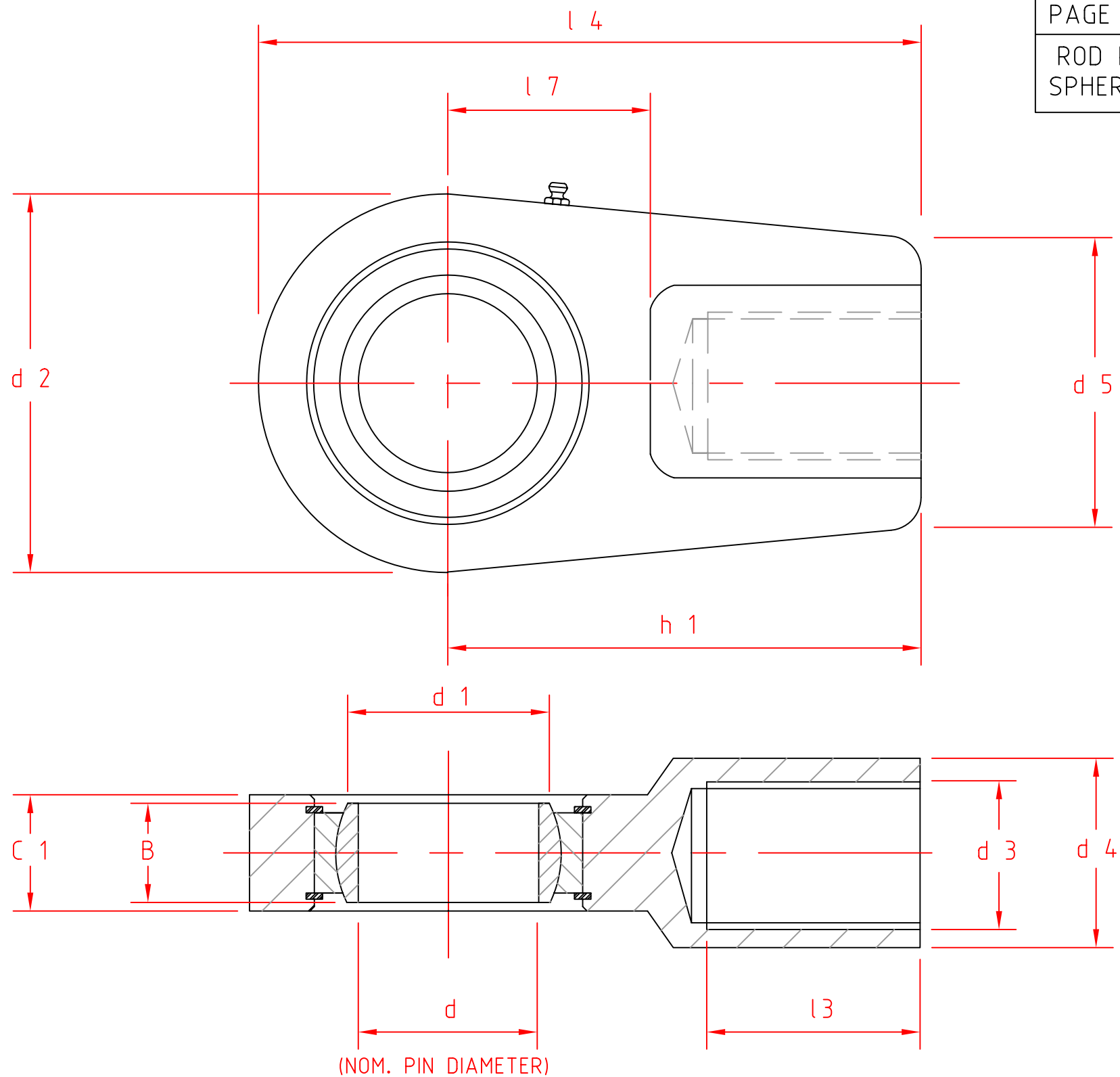

ROD KNUCKLE WITH SPHERICAL BEARING (RKSb)

NOTE

When ordering SPHERICAL BEARING ROD KNUCKLE
e.g. ROD KNUCKLE with 100 mm. dia. pin size
please quote RKSb100

PART NUMBER	C O	d	d 1	d 2	THREAD d 3	d 4	d 5	B	C 1	h 1	l 3	l 4	l 7
RKSb-20	72 kN	20mm -0,010	0.95" 24.10	2.20" 56.0	M16 x 1.5	0.98" 25.0	1.61" 41.0	0.629" 16.00	0.75" 19.0	1.97" 50.0	0.67" 17.0	3.07" 78.0	0.98" 25.0
RKSb-25	72 kN	25mm -0,010	1.15" 29.3	2.20" 56.0	M16 x 1.5	0.98" 25.0	1.61" 41.0	0.787" 20.00	0.90" 23.0	1.97" 50.0	0.67" 17.0	3.07" 78.0	0.98" 25.0
RKSb-30	106 kN	30mm -0,010	1.35" 34.2	2.52" 64.0	M22 x 1.5	1.26" 32.0	1.81" 46.0	0.866" 22.00	1.10" 28.0	2.36" 60.0	0.90" 23.0	3.62" 92.0	1.18" 30.0
RKSb-35	153 kN	35mm -0,012	1.56" 39.7	3.07" 78.0	M28 x 1.5	1.57" 40.0	2.28" 58.0	0.984" 25.00	1.18" 30.0	2.75" 70.0	1.14" 29.0	4.29" 109.0	1.49" 38.0
RKSb-40	250 kN	40mm -0,012	1.77" 45.0	3.70" 94.0	M35 x 1.5	1.93" 49.0	2.59" 66.0	1.102" 28.00	1.38" 35.0	3.34" 85.0	1.41" 36.0	5.19" 132.0	1.77" 45.0
RKSb-50	365 kN	50mm -0,012	2.20" 55.9	4.56" 116.0	M45 x 1.5	2.40" 61.0	3.46" 88.0	1.378" 35.00	1.57" 40.0	4.13" 105.0	1.81" 46.0	6.41" 163.0	2.16" 55.0
RKSb-60	400 kN	60mm -0,015	2.63" 66.8	5.11" 130.0	M58 x 1.5	2.95" 75.0	3.54" 90.0	1.732" 44.00	1.96" 50.0	5.11" 130.0	2.32" 59.0	7.87" 200.0	2.56" 65.0
RKSb-70	540 kN	70mm -0,015	3.06" 77.8	6.06" 154.0	M65 x 1.5	3.38" 86.0	3.94" 100.0	1.929" 49.00	2.16" 55.0	5.90" 150.0	2.59" 66.0	9.13" 232.0	2.95" 75.0
RKSb-80	670 kN	80mm -0,015	3.52" 89.4	6.93" 176.0	M80 x 2.0	4.01" 102.0	4.92" 125.0	2.165" 55.00	2.36" 60.0	6.69" 170.0	3.19" 81.0	10.43" 265.0	3.15" 80.0
RKSb-90	980 kN	90mm -0,020	3.86" 98.1	8.11" 206.0	M100 x 2.0	4.88" 124.0	5.75" 146.0	2.362" 60.00	2.56" 65.0	8.26" 210.0	3.97" 101.0	12.71" 323.0	3.54" 90.0
RKSb-100	1120 kN	100mm -0,020	4.31" 109.5	9.05" 230.0	M110 x 2.0	5.43" 138.0	6.53" 166.0	2.755" 70.00	2.75" 70.0	9.25" 235.0	4.37" 111.0	14.17" 360.0	4.13" 105.0

C O = STATIC LOAD CAPACITY. (FROM MANUFACTURES CATALOGUE)

FOR SIZES OR LOAD CAPACITY LARGER THAN RKSb-100

OR SPECIAL REQUIREMENTS REFER TO "HYDROIL"

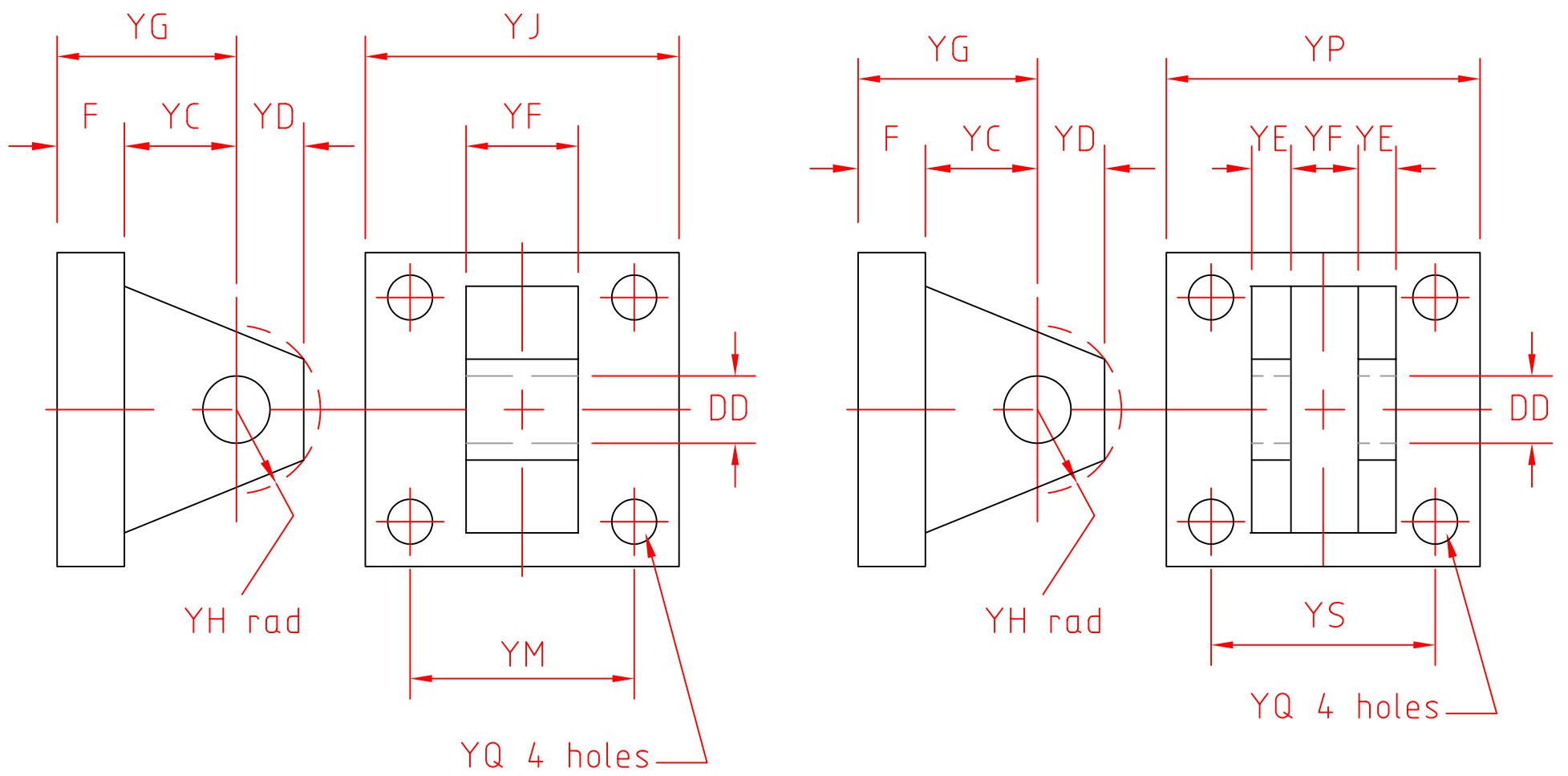

MALE BRACKET (MB)

For hole DD use B.S.1916 H8 fit.

FEMALE BRACKET (FB)

For hole DD use B.S.1916 H8 fit.

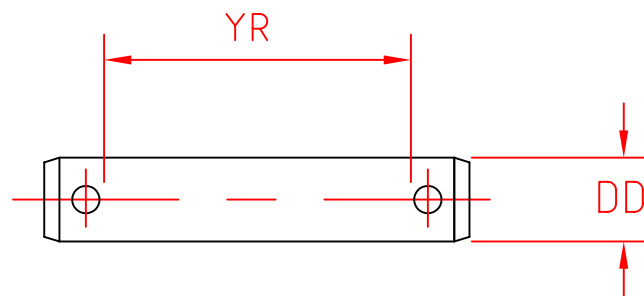

CLEVIS PIN (CP)

For pin use B.S.1916 f8 fit

NOTE

When ORDERING ACCESSORIES please relate appropriate abbreviation followed by part number.

e.g. MALE BRACKET for cylinder with 1.00" dia. rod.
please quote MB100

PART No.	ROD Dia.EE	THREAD GG	D D	Y R	Y H RAD	Y D	Y G	Y C	F	Y J	Y M	Y Q	Y P	Y S	Y E	Y F	PART No.
50	0.500" 12.7	5/16"-24	0.44" 11.11	0.88" 22.22	0.50" 12.70	0.44" 11.11	0.88" 22.22	0.50" 12.70	0.38" 9.52	2.25" 57.15	1.75" 44.45	0.27" 6.85	2.25" 57.15	1.75" 44.45	0.22" 5.6	0.44" 11.11	50
63	0.625" 15.87	7/16"-20	0.50" 12.70	1.75" 44.45	0.63" 15.87	0.50" 12.70	1.13" 28.57	0.75" 19.05	0.38" 9.52	2.50" 63.5	1.63" 41.27	0.41" 10.4	3.50" 88.9	2.55" 64.80	0.50" 12.70	0.75" 19.05	63
100	1.000" 25.4	3/4"-16	0.75" 19.05	2.50" 63.5	0.94" 23.81	0.75" 19.05	1.88" 47.62	1.25" 31.75	0.63" 15.87	3.50" 88.9	2.55" 64.80	0.53" 13.5	5.00" 127	3.82" 97.02	0.63" 15.87	1.25" 31.75	100
138	1.375" 34.92	1.00"-14	1.00" 25.4	3.00" 76.2	1.19" 31.10	1.00" 25.4	2.25" 57.15	1.50" 38.1	0.75" 19.05	4.50" 114.3	3.25" 82.55	0.66" 16.6	6.50" 165.1	4.95" 125.6	0.75" 19.05	1.50" 38.1	138
175	1.750" 44.45	1,1/4"-12	1.38" 34.92	4.00" 101.6	1.63" 41.27	1.38" 34.92	3.00" 76.2	2.13" 53.97	0.88" 22.22	5.00" 127	3.82" 97.02	0.66" 16.6	7.50" 190.5	5.73" 145.5	1.00" 25.4	2.00" 50.8	175
200	2.000" 50.8	1,1/2"-12	1.75" 44.45	5.00" 127	2.13" 53.97	1.75" 44.45	3.13" 79.37	2.25" 57.15	0.88" 22.22	6.50" 165.1	4.95" 125.6	0.91" 23.1	9.50" 241.3	7.50" 190.5	1.25" 31.75	2.50" 63.5	200
250	2.500" 63.5	1,7/8"-12	2.00" 50.8	5.00" 127	2.38" 60.32	2.00" 50.8	3.50" 88.9	2.50" 63.5	1.00" 25.4	7.50" 190.5	5.73" 145.5	1.06" 26.9	12.75" 323.85	9.40" 238.3	1.25" 31.75	2.50" 63.5	250
300	3.000" 76.2	2,1/4"-12	2.50" 63.5	6.00" 152.4	2.88" 73.02	2.50" 63.5	4.00" 101.6	3.00" 76.2	1.00" 25.4	8.50" 215.9	6.58" 167.2	1.19" 30.2	12.75" 323.85	9.40" 238.3	1.50" 38.1	3.00" 76.2	300
350	3.500" 88.9	2,1/2"-12	3.00" 76.2	6.00" 152.4	3.18" 80.77	3.00" 76.2	4.25" 107.95	3.25" 82.55	1.00" 25.4	9.50" 241.3	7.50" 190.5	1.31" 33.3	12.75" 323.85	9.40" 238.3	1.50" 38.1	3.00" 76.2	350

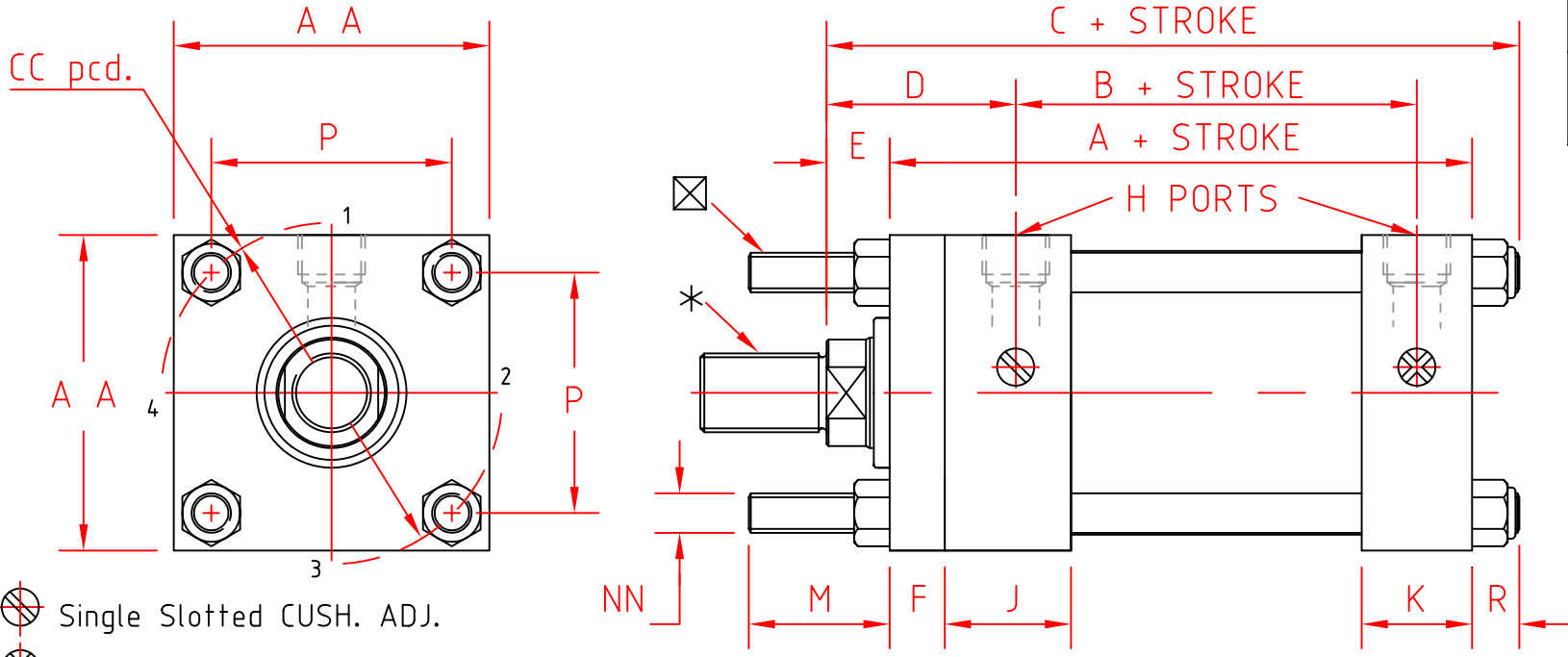

- ⊗ Single Slotted CUSH. ADJ.
- ⊗ Cross Slotted CUSH. Relief (Fixed)
- * MALE ROD END SHOWN See sheet 4 for male & female variations and dimensions
- ⊗ Variation of TIE ROD mounting on application

STYLE	NFPA	TIE ROD EXTENDED
1	MX3	HEAD END ONLY
1A	MX2	CAP END ONLY
1B	MX1	BOTH ENDS

CYLINDER SIZE	ROD DIA. E E	E	C	D	A	AA	B	F	H BSPP.	J	K	R	M	NN UNF.	P	CC
HB 15 1.50" BORE	0.625" STD. 15.87	0.63" 15.87	6.13" 155.57	2.00" 50.8	5.00" 127.0	2.50" 63.5	2.88" 73.02	0.38" 9.52	1/2"	1.75" 44.45	1.50" 38.1	0.50" 12.7	1.38" 34.92	3/8"-24	1.63" 41.4	2.30" 58.4
	1.000" 25.4	1.00" 25.4	6.50" 165.1	2.38" 60.32												
HB 20 2.00" BORE	1.000" STD. 25.4	0.75" 19.05	6.63" 168.27	2.38" 60.32	5.25" 133.35	3.00" 76.2	2.88" 73.02	0.62" 15.87	1/2"	1.75" 44.45	1.50" 38.1	0.63" 15.87	1.81" 46.03	1/2"-20	2.05" 52.07	2.90" 73.6
	1.375" 34.92	1.00" 25.4	6.88" 174.63	2.63" 66.68												
HB 25 2.50" BORE	1.000" STD. 25.4	0.75" 19.05	6.75" 171.45	2.38" 60.32	5.38" 136.52	3.50" 88.9	3.00" 76.2	0.62" 15.87	1/2"	1.75" 44.45	1.50" 38.1	0.63" 15.87	1.81" 46.03	1/2"-20	2.55" 64.7	3.60" 91.5
	1.375" 34.92	1.00" 25.4	7.00" 177.8	2.63" 66.68												
	1.750" 44.45	1.25" 31.75	7.25" 184.15	2.88" 73.02												
HB 32 3.25" BORE	1.375" STD. 34.92	0.88" 22.22	7.88" 200.02	2.75" 69.85	6.25" 158.75	4.50" 114.3	3.50" 88.9	0.75" 19.05	3/4"	2.00" 50.8	1.75" 44.45	0.75" 19.05	2.31" 58.73	5/8"-18	3.25" 82.55	4.6" 116.8
	1.750" 44.45	1.13" 28.57	8.13" 206.5	3.00" 76.2												
	2.000" 50.8	1.25" 31.75	8.25" 209.5	3.13" 79.38												
HB 40 4.00" BORE	1.750" STD. 44.45	1.00" 25.4	8.38" 212.72	3.00" 76.2	6.63" 168.27	5.00" 127.0	3.75" 95.25	0.88" 22.22	3/4"	2.00" 50.8	1.75" 44.45	0.75" 19.05	2.31" 58.73	5/8"-18	3.82" 97.0	5.4" 137.2
	2.000" 50.8	1.13" 28.57	8.50" 215.9	3.13" 79.37												
	2.500" 63.5	1.38" 34.92	8.75" 222.25	3.38" 85.73												
HB 50 5.00" BORE	2.000" STD. 50.8	1.13" 28.57	9.31" 236.53	3.13" 79.37	7.13" 180.97	6.50" 165.1	4.25" 107.95	0.88" 22.22	3/4"	2.00" 50.8	1.75" 44.45	1.06" 26.98	3.19" 80.96	7/8"-14	4.95" 125.7	7.0" 177.8
	2.500" 63.5	1.38" 34.92	9.56" 242.88	3.38" 85.73												
	3.000" 76.2	1.38" 34.92	9.56" 242.88	3.38" 85.73												
	3.500" 88.9	1.38" 34.92	9.56" 242.88	3.38" 85.73												
HB 60 6.00" BORE	2.500" STD. 63.5	1.25" 31.75	10.75" 273.05	3.50" 88.9	8.38" 212.72	7.50" 190.50	4.88" 132.82	1.00" 25.4	1.00"	2.25" 57.15	2.25" 57.15	1.12" 28.57	3.63" 92.07	1.00"-14	5.73" 145.5	8.1" 205.75
	3.000" 76.2	1.25" 31.75														
	3.500" 88.9	1.25" 31.75														
	4.000" 101.6	1.25" 31.75														
HB 70 7.00" BORE	3.000" STD. 76.2	1.25" 31.75	12.00" 304.8	3.81" 96.83	9.50" 241.3	8.50" 215.9	5.38" 136.52	1.00" 25.4	1,1/4"	2.75" 69.85	2.75" 69.85	1.25" 31.75	4.13" 104.77	1,1/8"-12	6.58" 167.1	9.3" 236.22
	3.500" 88.9	1.25" 31.75														
	4.000" 101.6	1.25" 31.75														
	5.000" 127.0	1.25" 31.75														
HB 80 8.00" BORE	3.500" STD. 88.9	1.25" 31.75	13.12" 333.37	3.94" 100.0	10.50" 266.7	9.50" 241.3	6.13" 155.57	1.00" 25.4	1,1/2"	3.00" 76.2	3.00" 76.2	1.38" 34.92	4.50" 114.3	1,1/4"-12	7.50" 190.5	10.6" 269.2
	4.000" 101.6	1.25" 31.75														
	5.000" 127.0	1.25" 31.75														
	5.500" 139.7	1.25" 31.75														

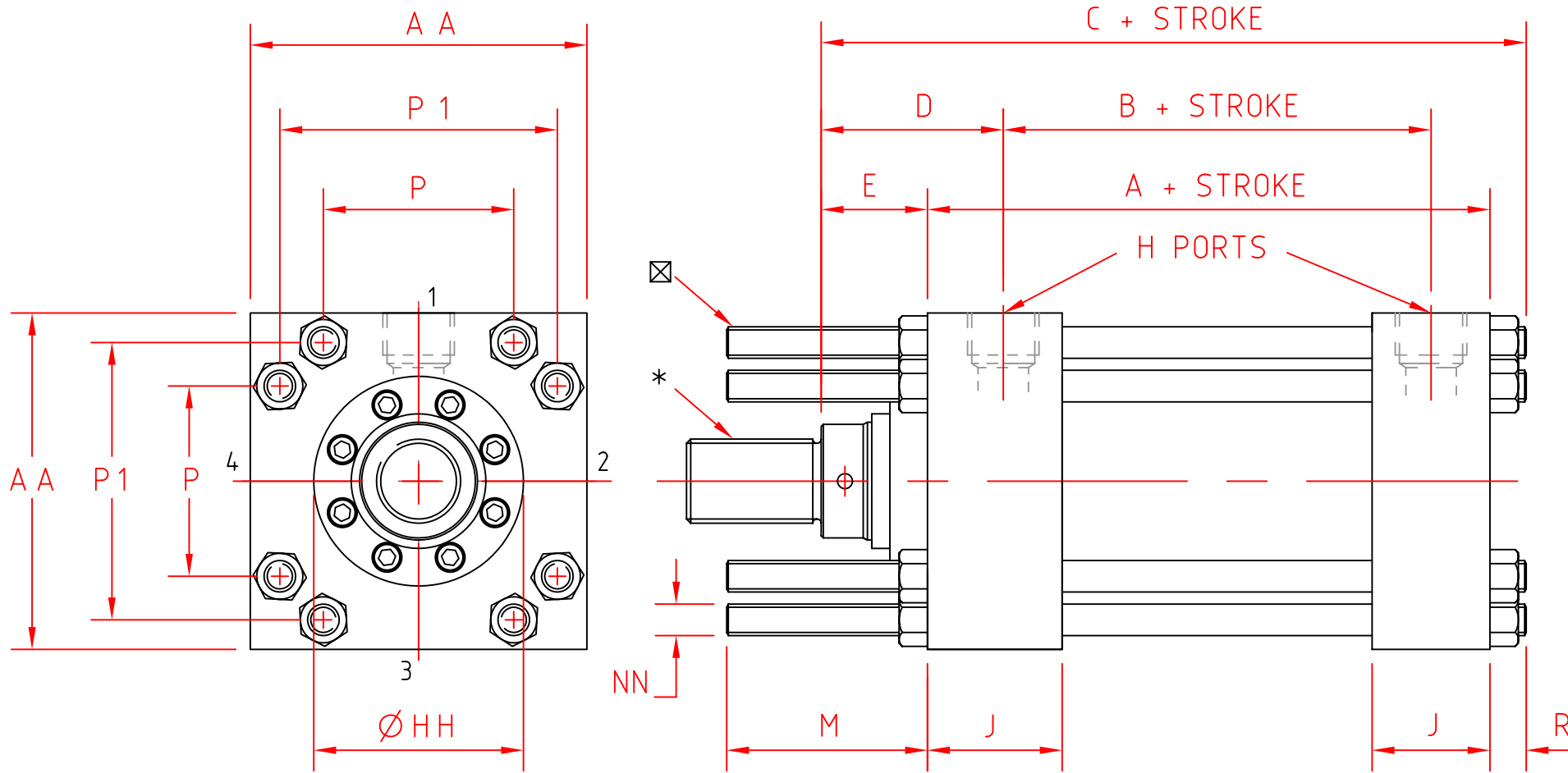

STYLE	NFPA	TIE ROD EXTENDED
1	MX3	HEAD END ONLY
1A	MX2	CAP END ONLY
1B	MX1	BOTH ENDS

* MALE ROD END SHOWN See sheet 4A for male & female variations and dimensions

☒ Variation of TIE ROD mounting on application

⊗ Single Slotted CUSH. ADJ.

⊗ Cross Slotted CUSH. Relief (Fixed)

CYLINDER SIZE	ROD DIA. E E	E	C	D	HH Ø	A	AA	B	H	J	R	M	NN UNF.	P	P 1
HB 100 10.00" BORE	4.50" 114.3	2.94" 74.6	16.63" 422.27	4.75" 120.65	8.25" 209.55	12.13" 307.97	12.63" 320.67	8.50" 215.90	2.00" BSPP.	3.69" 93.65	1.56" 39.68	4.13" 104.77	1,1/8"-12	7.50" 190.50	10.625" 269.87
	5.00" STD. 127.0	3.19" 80.95	16.88" 428.63	5.00" 127.0	8.75" 222.25										
	5.50" 139.7	3.19" 80.95	16.88" 428.63	5.00" 127.0	9.38" 238.13										
	7.00" 177.8	3.50" 88.9	17.19" 436.56	5.31" 134.93	10.5" 266.7										
HB 120 12.00" BORE	5.50" 139.7	3.19" 80.95	19.78" 502.4	5.44" 138.09	9.38" 238.13	14.5" 368.30	14.88" 377.82	10.00" 254.00	2.50" SAE.	4.44" 112.71	2.09" 53.08	4.50" 114.30	1,1/4"-12	9.125" 231.77	12.562" 319.08
	7.00" STD. 177.8	3.50" 88.9	20.09" 510.28	5.75" 146.05	10.5" 266.7										
	8.00" 203.2	4.00" 101.6	20.59" 522.98	6.25" 158.75	12.5" 317.5										

STYLE 2
HEAD
RECTANGULAR
FLANGE

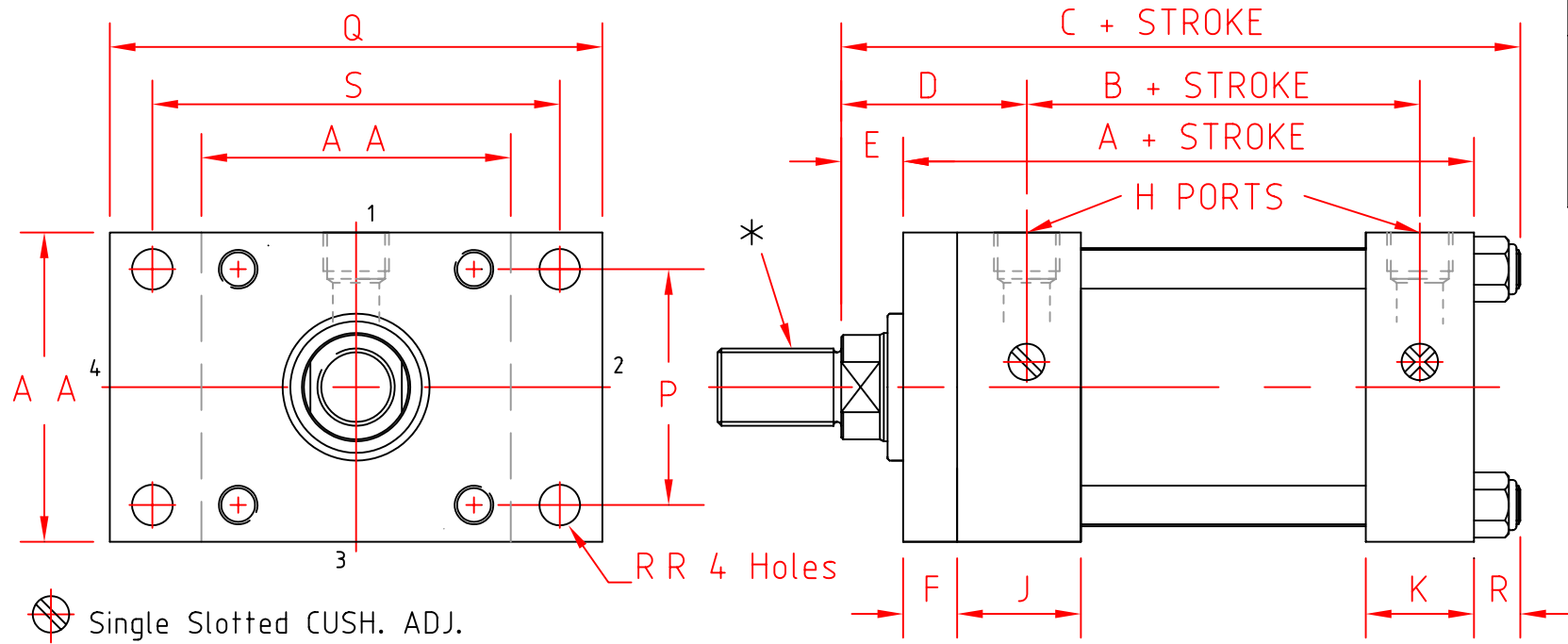



- ⊗ Single Slotted CUSH. ADJ.
- ⊗ Cross Slotted CUSH. Relief (Fixed)
- * MALE ROD END SHOWN See sheet 4 for male & female variations and dimensions

CYLINDER SIZE	ROD DIA. E E	E	C	D	A	AA	B	F	H BSPP.	J	K	R	P	Q	RR	S
HB 15 1.50" BORE	0.625" STD. 15.87	0.63" 15.87	6.13" 155.57	2.00" 50.8	5.00" 127.0	2.50" 63.5	2.88" 73.02	0.38" 9.52	1/2"	1.75" 44.45	1.50" 38.1	0.50" 12.7	1.63" 41.4	4.25" 107.95	0.44" 11.11	3.44" 87.31
	1.000" 25.4	1.00" 25.4	6.50" 165.1	2.38" 60.32												
HB 20 2.00" BORE	1.000" STD. 25.4	0.75" 19.05	6.63" 168.27	2.38" 60.32	5.25" 133.35	3.00" 76.2	2.88" 73.02	0.62" 15.87	1/2"	1.75" 44.45	1.50" 38.1	0.63" 15.87	2.05" 52.07	5.13" 130.17	0.56" 14.28	4.13" 104.77
	1.375" 34.92	1.00" 25.4	6.88" 174.63	2.63" 66.68												
HB 25 2.50" BORE	1.000" STD. 25.4	0.75" 19.05	6.75" 171.45	2.38" 60.32	5.38" 136.52	3.50" 88.9	3.00" 76.2	0.62" 15.87	1/2"	1.75" 44.45	1.50" 38.1	0.63" 15.87	2.55" 64.7	5.63" 142.87	0.56" 14.28	4.63" 117.47
	1.375" 34.92	1.00" 25.4	7.00" 177.8	2.63" 66.68												
	1.750" 44.45	1.25" 31.75	7.25" 184.15	2.88" 73.02												
HB 32 3.25" BORE	1.375" STD. 34.92	0.88" 22.22	7.88" 200.02	2.75" 69.85	6.25" 158.75	4.50" 114.3	3.50" 88.9	0.75" 19.05	3/4"	2.00" 50.8	1.75" 44.45	0.75" 19.05	3.25" 82.55	7.13" 180.97	0.69" 17.46	5.88" 149.22
	1.750" 44.45	1.13" 28.57	8.13" 206.5	3.00" 76.2												
	2.000" 50.8	1.25" 31.75	8.25" 209.5	3.13" 79.38												
HB 40 4.00" BORE	1.750" STD. 44.45	1.00" 25.4	8.38" 212.72	3.00" 76.2	6.63" 168.27	5.00" 127.0	3.75" 95.25	0.88" 22.22	3/4"	2.00" 50.8	1.75" 44.45	0.75" 19.05	3.82" 97.0	7.63" 193.67	0.69" 17.46	6.38" 161.92
	2.000" 50.8	1.13" 28.57	8.50" 215.9	3.13" 79.37												
	2.500" 63.5	1.38" 34.92	8.75" 222.25	3.38" 85.73												
HB 50 5.00" BORE	2.000" STD. 50.8	1.13" 28.57	9.31" 236.53	3.13" 79.37	7.13" 180.97	6.50" 165.1	4.25" 107.95	0.88" 22.22	3/4"	2.00" 50.8	1.75" 44.45	1.06" 26.98	4.95" 125.7	9.75" 247.65	0.94" 23.81	8.19" 207.96
	2.500" 63.5	1.38" 34.92	9.56" 242.88	3.38" 85.73												
	3.000" 76.2	1.38" 34.92	9.56" 242.88	3.38" 85.73												
	3.500" 88.9	1.38" 34.92	9.56" 242.88	3.38" 85.73												
HB 60 6.00" BORE	2.500" STD. 63.5	1.25" 31.75	10.75" 273.05	3.50" 88.9	8.38" 212.72	7.50" 190.50	4.88" 132.82	1.00" 25.4	1.00"	2.25" 57.15	2.25" 57.15	1.12" 28.57	5.73" 145.5	11.25" 285.75	1.06" 26.98	9.44" 239.71
	3.000" 76.2	1.25" 31.75														
	3.500" 88.9	1.25" 31.75														
	4.000" 101.6	1.25" 31.75														
HB 70 7.00" BORE	3.000" STD. 76.2	1.25" 31.75	12.00" 304.8	3.81" 96.83	9.50" 241.3	8.50" 215.9	5.38" 136.52	1.00" 25.4	1 1/4"	2.75" 69.85	2.75" 69.85	1.25" 31.75	6.58" 167.1	12.63" 320.67	1.19" 30.16	10.63" 269.87
	3.500" 88.9	1.25" 31.75														
	4.000" 101.6	1.25" 31.75														
	5.000" 127.0	1.25" 31.75														
HB 80 8.00" BORE	3.500" STD. 88.9	1.25" 31.75	13.12" 333.37	3.94" 100.0	10.50" 266.7	9.50" 241.3	6.13" 155.57	1.00" 25.4	1 1/2"	3.00" 76.2	3.00" 76.2	1.38" 34.92	7.50" 190.5	14.00" 355.6	1.31" 33.33	11.81" 300.03
	4.000" 101.6	1.25" 31.75														
	5.000" 127.0	1.25" 31.75														
	5.500" 139.7	1.25" 31.75														

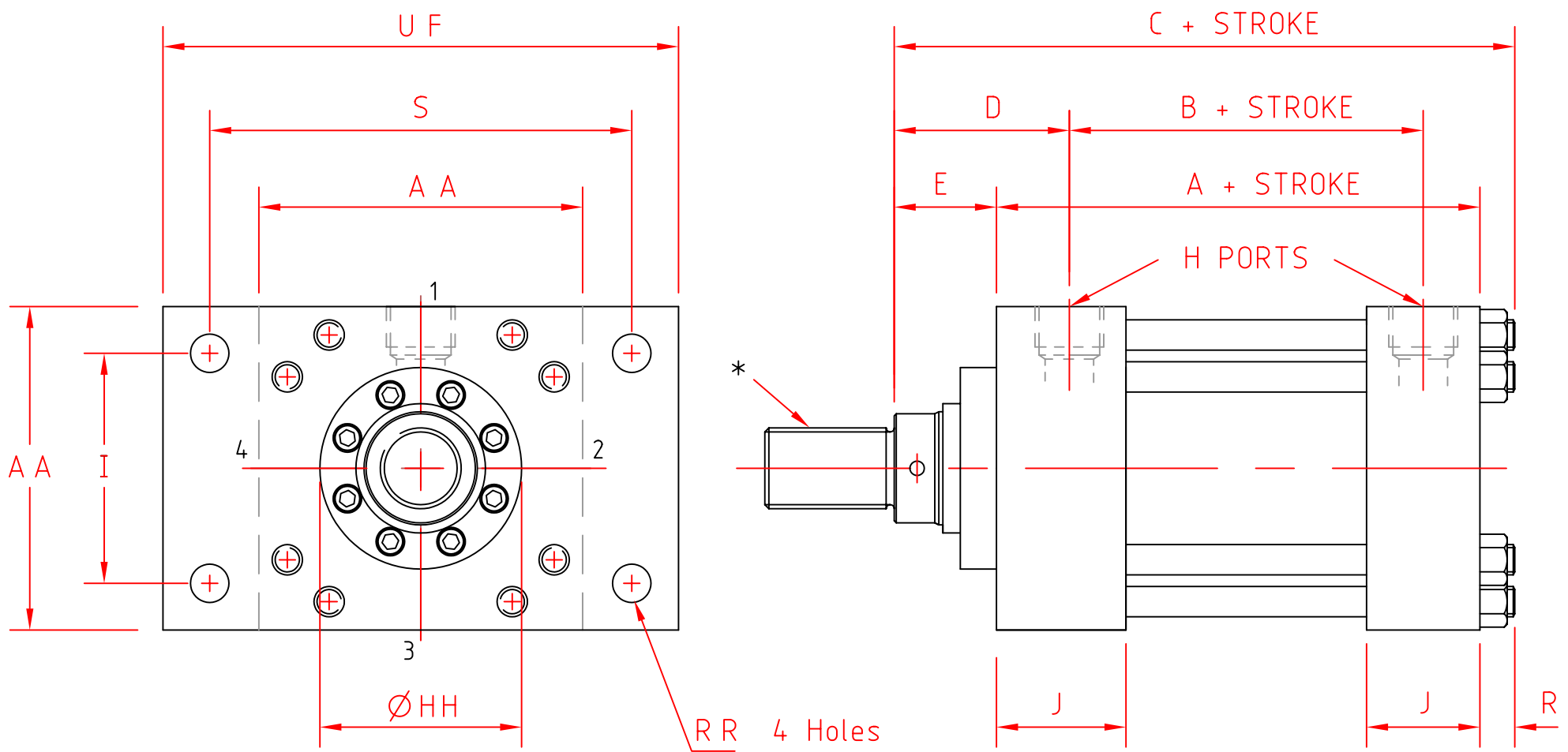
STYLE 2
HEAD
RECTANGULAR
FLANGE



* MALE ROD END SHOWN See sheet 4A for male & female variations and dimensions

-  Single Slotted CUSH. ADJ.
-  Cross Slotted CUSH. Relief (Fixed)

CYLINDER SIZE	ROD DIA. E E	E	C	D	HH ϕ	A	AA	B	H	J	R	UF	S	I	RR ϕ
HB 100 10.00" BORE	4.50" 114.3	2.94" 74.6	16.63" 422.27	4.75" 120.65	8.25" 209.55	12.13" 307.97	12.63" 320.67	8.50" 215.90	2.00" BSPP.	3.69" 93.65	1.56" 39.68	19.00" 482.6	15.875" 403.22	9.62" 244.34	1.81" 46.02
	5.00" STD. 127.0	3.19" 80.95	16.88" 428.63	5.00" 127.0	8.75" 222.25										
	5.50" 139.7	3.19" 80.95	16.88" 428.63	5.00" 127.0	9.38" 238.13										
	7.00" 177.8	3.50" 88.9	17.19" 436.56	5.31" 134.93	10.5" 266.7										
HB 120 12.00" BORE	5.50" 139.7	3.19" 80.95	19.78" 502.4	5.44" 138.09	9.38" 238.13	14.5" 368.30	14.88" 377.82	10.00" 254.00	2.50" SAE.	4.44" 112.71	2.09" 53.08	22.00" 558.8	18.500" 469.90	11.45" 290.83	2.06" 52.37
	7.00" STD. 177.8	3.50" 88.9	20.09" 510.28	5.75" 146.05	10.5" 266.7										
	8.00" 203.2	4.00" 101.6	20.59" 522.98	6.25" 158.75	12.5" 317.5										

STYLE 3
CAP
RECTANGULAR
FLANGE

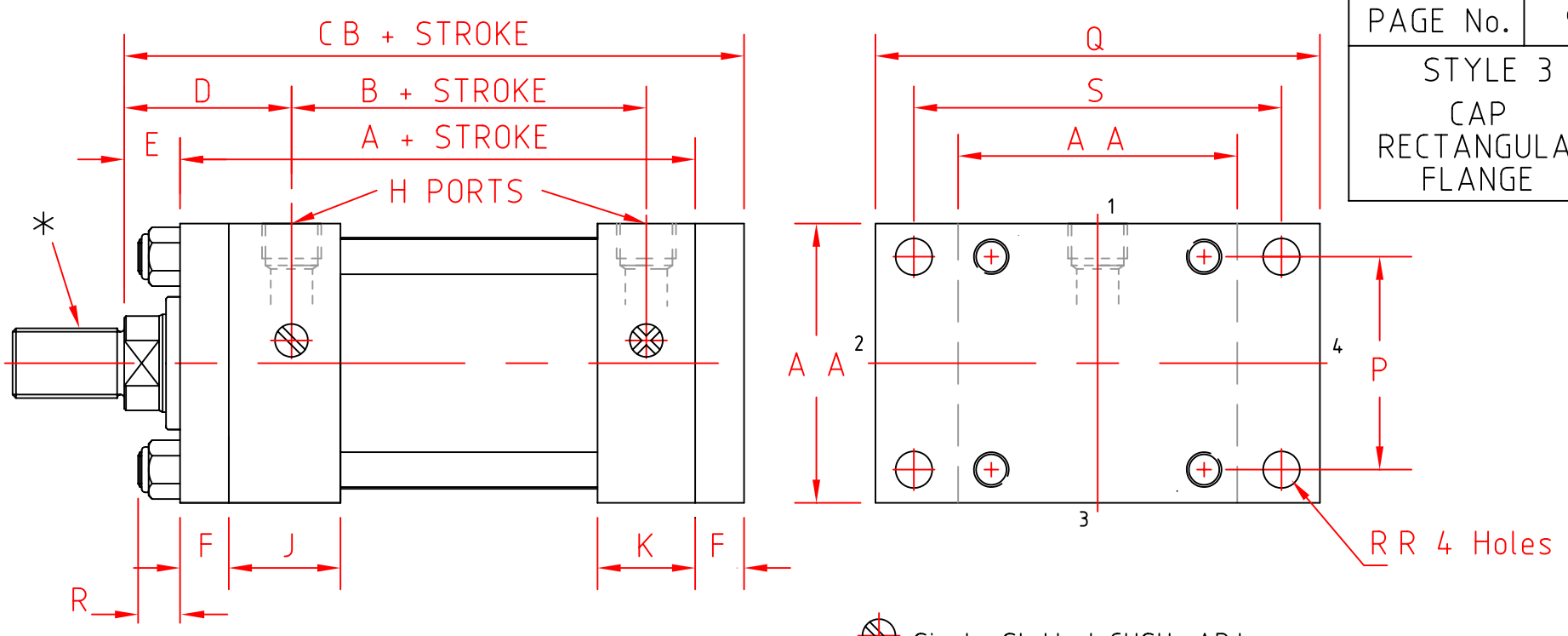

* MALE ROD END SHOWN See sheet 4 for male & female variations and dimensions

- Single Slotted CUSH. ADJ.
- Cross Slotted CUSH. Relief (Fixed)

CYLINDER SIZE	ROD DIA. E E	E	CB	D	A	AA	B	F	H BSPP.	J	K	R	P	Q	RR	S
HB 15 1.50" BORE	0.625" STD. 15.87	0.63" 15.87	6.00" 152.4	2.00" 50.8	5.00"	2.50"	2.88"	0.38"	1/2"	1.75"	1.50"	0.50"	1.63"	4.25"	0.44"	3.44"
	1.000" 25.4	1.00" 25.4	6.38" 161.92	2.38" 60.32	127.0	63.5	73.02	9.52		44.45	38.1	12.7	41.4	107.95	11.11	87.31
HB 20 2.00" BORE	1.000" STD. 25.4	0.75" 19.05	6.63" 168.27	2.38" 60.32	5.25"	3.00"	2.88"	0.62"	1/2"	1.75"	1.50"	0.63"	2.05"	5.13"	0.56"	4.13"
	1.375" 34.92	1.00" 25.4	6.88" 174.62	2.63" 66.68	133.35	76.2	73.02	15.87		44.45	38.1	15.87	52.07	130.17	14.28	104.77
HB 25 2.50" BORE	1.000" STD. 25.4	0.75" 19.05	6.75" 171.45	2.38" 60.32	5.38"	3.50"	3.00"	0.62"	1/2"	1.75"	1.50"	0.63"	2.55"	5.63"	0.56"	4.63"
	1.375" 34.92	1.00" 25.4	7.00" 177.8	2.63" 66.68												
	1.750" 44.45	1.25" 31.75	7.25" 184.15	2.88" 73.02												
HB 32 3.25" BORE	1.375" STD. 34.92	0.88" 22.22	7.88" 200.02	2.75" 69.85	6.25"	4.50"	3.50"	0.75"	3/4"	2.00"	1.75"	0.75"	3.25"	7.13"	0.69"	5.88"
	1.750" 44.45	1.13" 28.57	8.13" 206.37	3.00" 76.2												
	2.000" 50.8	1.25" 31.75	8.25" 209.55	3.13" 79.38												
HB 40 4.00" BORE	1.750" STD. 44.45	1.00" 25.4	8.50" 215.9	3.00" 76.2	6.63"	5.00"	3.75"	0.88"	3/4"	2.00"	1.75"	0.75"	3.82"	7.63"	0.69"	6.38"
	2.000" 50.8	1.13" 28.57	8.63" 219.07	3.13" 79.37												
	2.500" 63.5	1.38" 34.92	8.88" 225.42	3.38" 85.73												
HB 50 5.00" BORE	2.000" STD. 50.8	1.13" 28.57	9.13" 231.77	3.13" 79.37	7.13"	6.50"	4.25"	0.88"	3/4"	2.00"	1.75"	1.06"	4.95"	9.75"	0.94"	8.19"
	2.500" 63.5	1.38" 34.92	9.38" 238.13	3.38" 85.73												
	3.000" 76.2	1.38" 34.92	9.38" 238.13	3.38" 85.73												
	3.500" 88.9	1.38" 34.92	9.38" 238.13	3.38" 85.73												
HB 60 6.00" BORE	2.500" STD. 63.5	1.25" 31.75	10.63"	3.50"	8.38"	7.50"	4.88"	1.00"	1.00"	2.25"	2.25"	1.12"	5.73"	11.25"	1.06"	9.44"
	3.000" 76.2	1.25" 31.75														
	3.500" 88.9	1.25" 31.75														
	4.000" 101.6	1.25" 31.75														
HB 70 7.00" BORE	3.000" STD. 76.2	1.25" 31.75	11.75"	3.81"	9.50"	8.50"	5.38"	1.00"	1,1/4"	2.75"	2.75"	1.25"	6.58"	12.63"	1.19"	10.63"
	3.500" 88.9	1.25" 31.75														
	4.000" 101.6	1.25" 31.75														
	5.000" 127.0	1.25" 31.75														
HB 80 8.00" BORE	3.500" STD. 88.9	1.25" 31.75	12.75"	3.94"	10.50"	9.50"	6.13"	1.00"	1,1/2"	3.00"	3.00"	1.38"	7.50"	14.00"	1.31"	11.81"
	4.000" 101.6	1.25" 31.75														
	5.000" 127.0	1.25" 31.75														
	5.500" 139.7	1.25" 31.75														

STYLE 3
CAP
RECTANGULAR
FLANGE

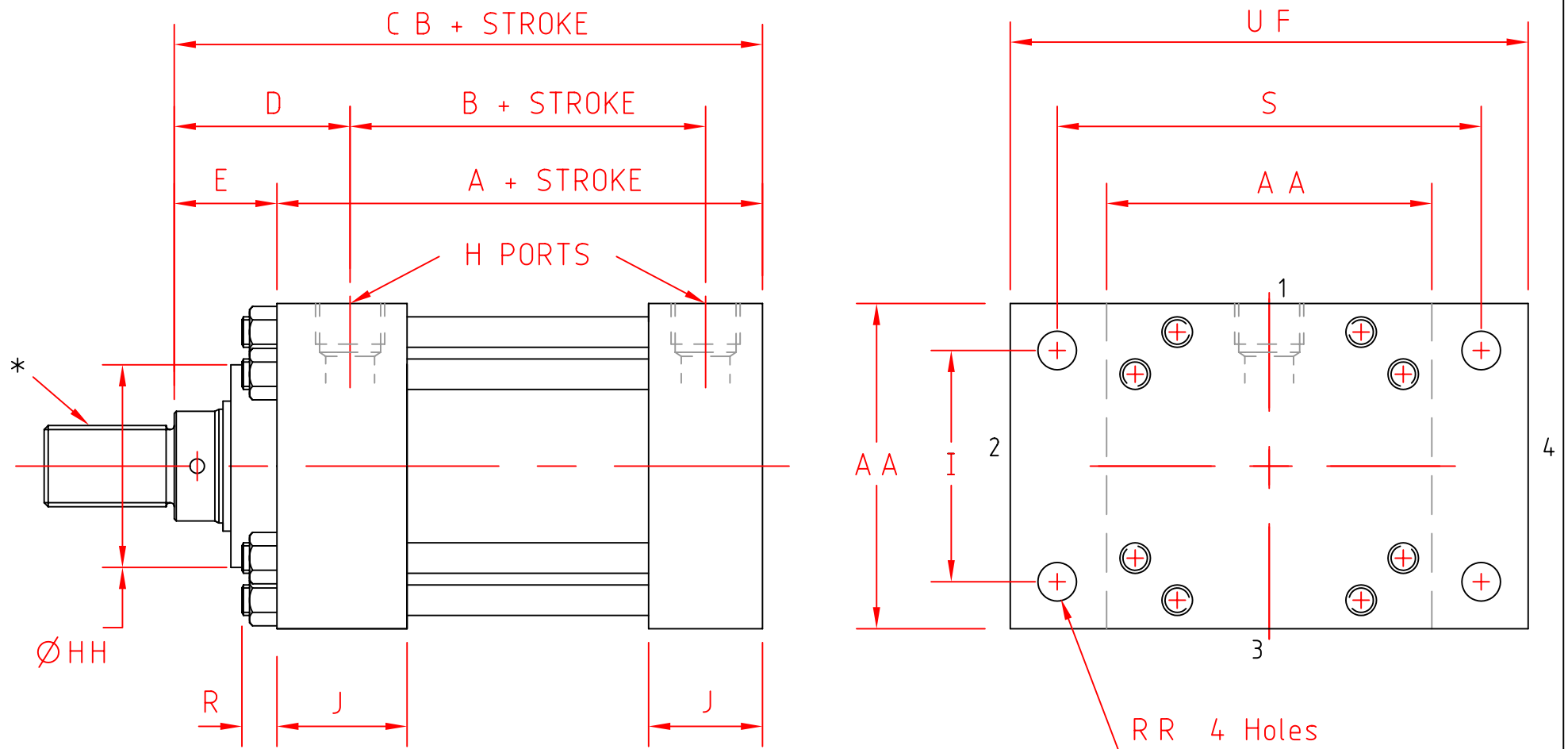

* MALE ROD END SHOWN See sheet 4A for male & female variations and dimensions

- Single Slotted CUSH. ADJ.
- Cross Slotted CUSH. Relief (Fixed)

CYLINDER SIZE	ROD DIA. E E	E	CB	D	HH Ø	A	AA	B	H	J	R	UF	S	I	R R Ø
HB 100 10.00" BORE	4.50" 114.3	2.94" 74.6	15.06" 382.57	4.75" 120.65	8.25" 209.55	12.13" 307.97	12.63" 320.67	8.50" 215.90	2.00" BSPP.	3.69" 93.65	1.56" 39.68	19.00" 482.6	15.875" 403.22	9.62" 244.34	1.81" 46.02
	5.00" STD. 127.0	3.19" 80.95	15.31" 388.93	5.00" 127.0	8.75" 222.25										
	5.50" 139.7	3.19" 80.95	15.31" 388.93	5.00" 127.0	9.38" 238.13										
	7.00" 177.8	3.50" 88.9	15.63" 396.87	5.31" 134.93	10.5" 266.7										
HB 120 12.00" BORE	5.50" 139.7	3.19" 80.95	17.69" 449.25	5.44" 138.09	9.38" 238.13	14.5" 368.30	14.88" 377.82	10.00" 254.00	2.50" SAE.	4.44" 112.71	2.09" 53.08	22.00" 558.8	18.500" 469.90	11.45" 290.83	2.06" 52.37
	7.00" STD. 177.8	3.50" 88.9	18.0" 457.20	5.75" 146.05	10.5" 266.7										
	8.00" 203.2	4.00" 101.6	18.5" 469.90	6.25" 158.75	12.5" 317.5										

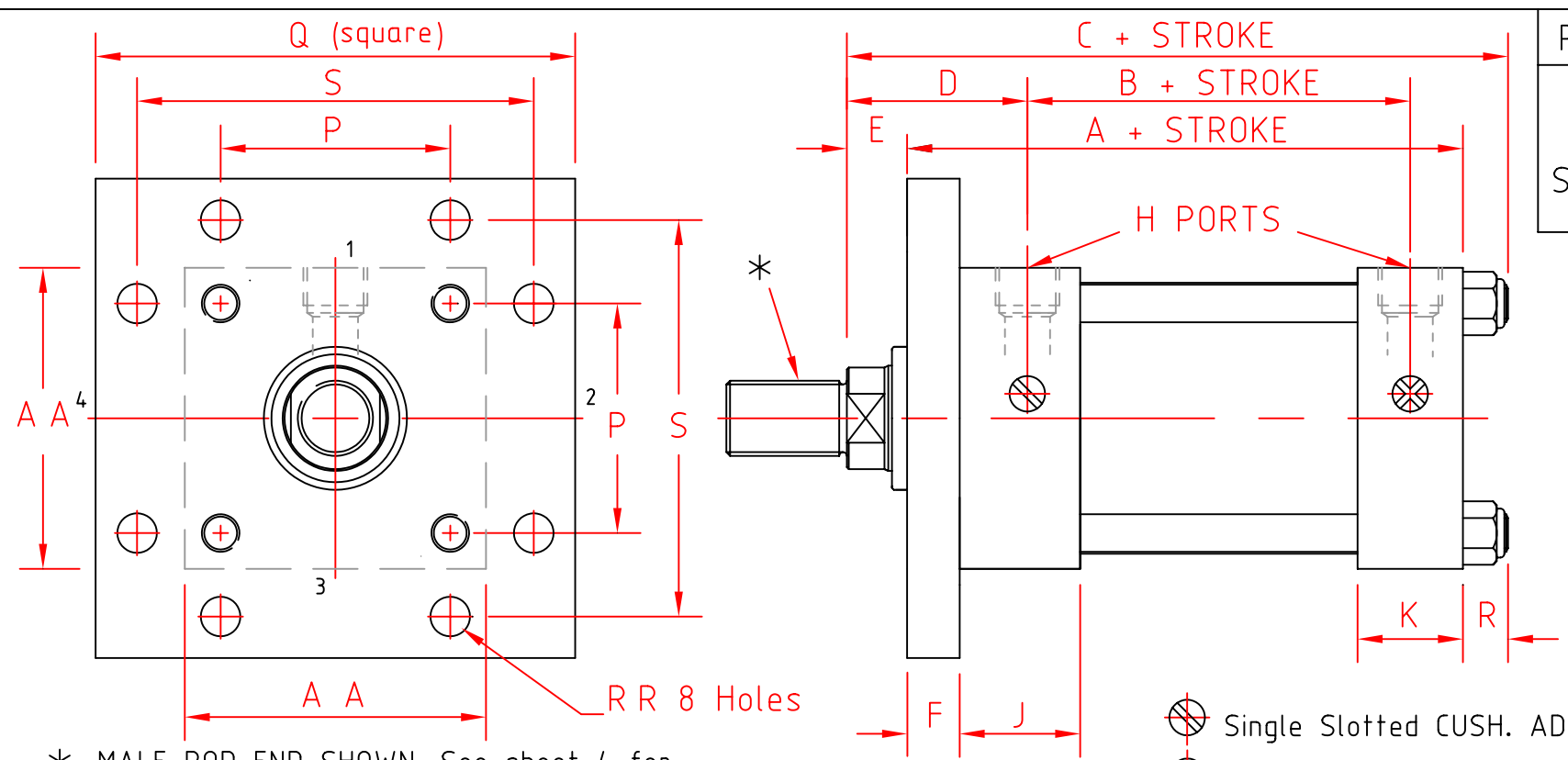

* MALE ROD END SHOWN See sheet 4 for male & female variations and dimensions



- Single Slotted CUSH. ADJ.
- Cross Slotted CUSH. Relief (Fixed)

CYLINDER SIZE	ROD DIA. E E	E	C	D	A	AA	B	F	H BSPP.	J	K	R	P	Q	RR	S
HB 15 1.50" BORE	0.625" STD. 15.87	0.63" 15.87	6.13" 155.57	2.00" 50.8	5.00"	2.50"	2.88"	0.38"	1/2"	1.75"	1.50"	0.50"	1.63"	4.25"	0.44"	3.44"
	1.000" 25.4	1.00" 25.4	6.50" 165.1	2.38" 60.32	127.0	63.5	73.02	9.52		44.45	38.1	12.7	41.4	107.95	11.11	87.31
HB 20 2.00" BORE	1.000" STD. 25.4	0.75" 19.05	6.63" 168.27	2.38" 60.32	5.25"	3.00"	2.88"	0.62"	1/2"	1.75"	1.50"	0.63"	2.05"	5.13"	0.56"	4.13"
	1.375" 34.92	1.00" 25.4	6.88" 174.63	2.63" 66.68	133.35	76.2	73.02	15.87		44.45	38.1	15.87	52.07	130.17	14.28	104.77
HB 25 2.50" BORE	1.000" STD. 25.4	0.75" 19.05	6.75" 171.45	2.38" 60.32	5.38"	3.50"	3.00"	0.62"	1/2"	1.75"	1.50"	0.63"	2.55"	5.63"	0.56"	4.63"
	1.375" 34.92	1.00" 25.4	7.00" 177.8	2.63" 66.68												
	1.750" 44.45	1.25" 31.75	7.25" 184.15	2.88" 73.02												
HB 32 3.25" BORE	1.375" STD. 34.92	0.88" 22.22	7.88" 200.02	2.75" 69.85	6.25"	4.50"	3.50"	0.75"	3/4"	2.00"	1.75"	0.75"	3.25"	7.13"	0.69"	5.88"
	1.750" 44.45	1.13" 28.57	8.13" 206.5	3.00" 76.2												
	2.000" 50.8	1.25" 31.75	8.25" 209.5	3.13" 79.38												
HB 40 4.00" BORE	1.750" STD. 44.45	1.00" 25.4	8.38" 212.72	3.00" 76.2	6.63"	5.00"	3.75"	0.88"	3/4"	2.00"	1.75"	0.75"	3.82"	7.63"	0.69"	6.38"
	2.000" 50.8	1.13" 28.57	8.50" 215.9	3.13" 79.37												
	2.500" 63.5	1.38" 34.92	8.75" 222.25	3.38" 85.73												
HB 50 5.00" BORE	2.000" STD. 50.8	1.13" 28.57	9.31" 236.53	3.13" 79.37	7.13"	6.50"	4.25"	0.88"	3/4"	2.00"	1.75"	1.06"	4.95"	9.75"	0.94"	8.19"
	2.500" 63.5	1.38" 34.92	9.56" 242.88	3.38" 85.73												
	3.000" 76.2	1.38" 34.92	9.56" 242.88	3.38" 85.73												
	3.500" 88.9	1.38" 34.92	9.56" 242.88	3.38" 85.73												
HB 60 6.00" BORE	2.500" STD. 63.5	1.25" 31.75	10.75"	3.50"	8.38"	7.50"	4.88"	1.00"	1.00"	2.25"	2.25"	1.12"	5.73"	11.25"	1.06"	9.44"
	3.000" 76.2	1.25" 31.75														
	3.500" 88.9	1.25" 31.75														
	4.000" 101.6	1.25" 31.75														
HB 70 7.00" BORE	3.000" STD. 76.2	1.25" 31.75	12.00"	3.81"	9.50"	8.50"	5.38"	1.00"	1,1/4"	2.75"	2.75"	1.25"	6.58"	12.63"	1.19"	10.63"
	3.500" 88.9	1.25" 31.75														
	4.000" 101.6	1.25" 31.75														
	5.000" 127.0	1.25" 31.75														
HB 80 8.00" BORE	3.500" STD. 88.9	1.25" 31.75	13.12"	3.94"	10.50"	9.50"	6.13"	1.00"	1,1/2"	3.00"	3.00"	1.38"	7.50"	14.00"	1.31"	11.81"
	4.000" 101.6	1.25" 31.75														
	5.000" 127.0	1.25" 31.75														
	5.500" 139.7	1.25" 31.75														

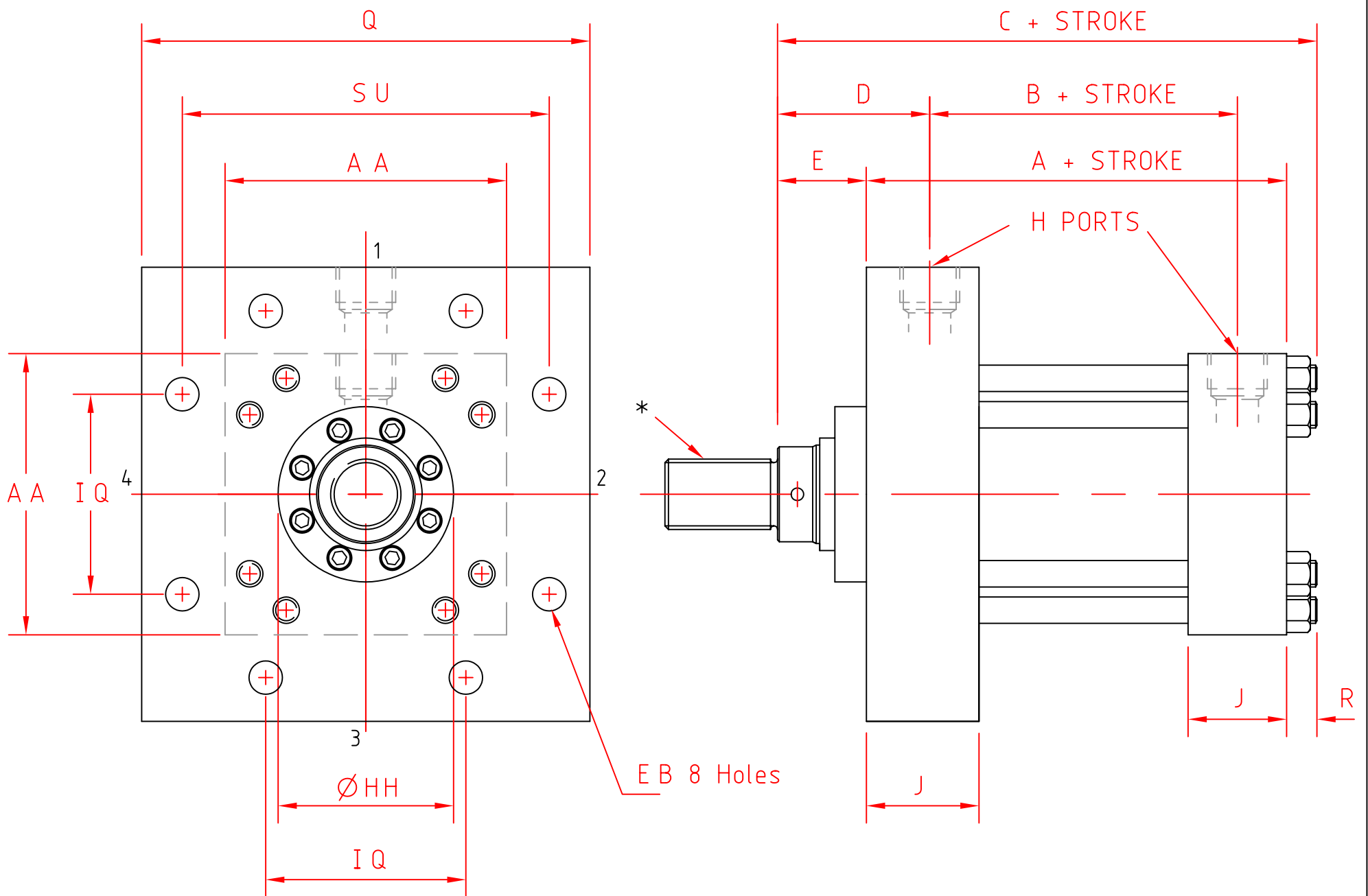
STYLE 4
HEAD
SQUARE FLANGE



* MALE ROD END SHOWN See sheet 4A for male & female variations and dimensions

-  Single Slotted CUSH. ADJ.
-  Cross Slotted CUSH. Relief (Fixed)

CYLINDER SIZE	ROD DIA. E E	E	C	D	HH ϕ	A	AA	B	H	J	R	Q	SU	IQ	EB ϕ
HB 100 10.00" BORE	4.50" 114.3	2.94" 74.6	16.63" 422.27	4.75" 120.65	8.25" 209.55	12.13" 307.97	12.63" 320.67	8.50" 215.90	2.00" BSPP.	3.69" 93.65	1.56" 39.68	16.63" 422.27	14.13" 358.77	9.89" 251.20	1.31" 33.33
	5.00" STD. 127.0	3.19" 80.95	16.88" 428.63	5.00" 127.0	8.75" 222.25										
	5.50" 139.7	3.19" 80.95	16.88" 428.63	5.00" 127.0	9.38" 238.13										
	7.00" 177.8	3.50" 88.9	17.19" 436.56	5.31" 134.93	10.5" 266.7										
HB 120 12.00" BORE	5.50" 139.7	3.19" 80.95	19.78" 502.4	5.44" 138.09	9.38" 238.13	14.5" 368.30	14.88" 377.82	10.00" 254.00	2.50" SAE.	4.44" 112.71	2.09" 53.08	19.75" 501.65	16.79" 426.46	11.75" 298.45	1.56" 39.68
	7.00" STD. 177.8	3.50" 88.9	20.09" 510.28	5.75" 146.05	10.5" 266.7										
	8.00" 203.2	4.00" 101.6	20.59" 522.98	6.25" 158.75	12.5" 317.5										

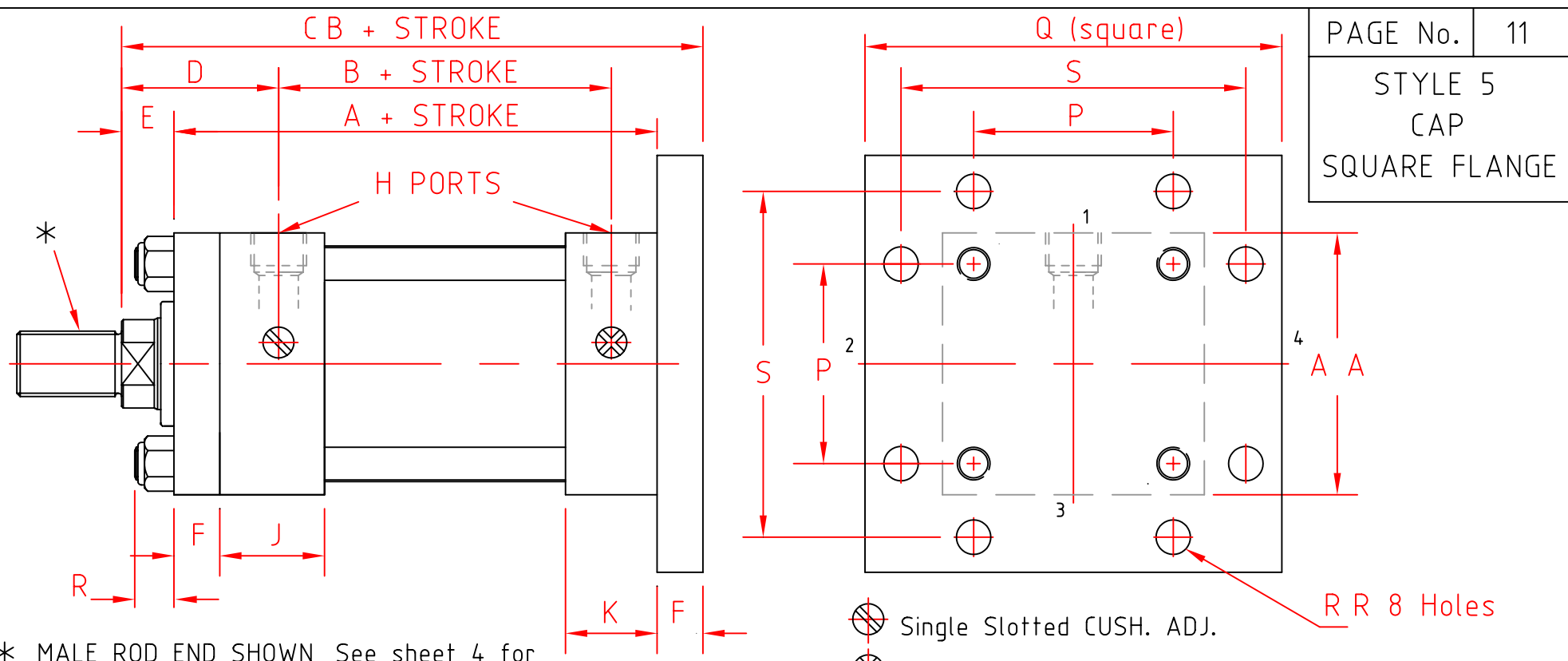

* MALE ROD END SHOWN See sheet 4 for male & female variations and dimensions

⊗ Single Slotted CUSH. ADJ.
⊗ Cross Slotted CUSH. Relief (Fixed)
R R 8 Holes

CYLINDER SIZE	ROD DIA. E E	E	CB	D	A	AA	B	F	H BSPP.	J	K	R	P	Q	RR	S
HB 15 1.50" BORE	0.625" STD. 15.87	0.63" 15.87	6.00" 152.4	2.00" 50.8	5.00"	2.50"	2.88"	0.38"	1/2"	1.75"	1.50"	0.50"	1.63"	4.25"	0.44"	3.44"
	1.000" 25.4	1.00" 25.4	6.38" 161.92	2.38" 60.32	127.0	63.5	73.02	9.52		44.45	38.1	12.7	41.4	107.95	11.11	87.31
HB 20 2.00" BORE	1.000" STD. 25.4	0.75" 19.05	6.63" 168.27	2.38" 60.32	5.25"	3.00"	2.88"	0.62"	1/2"	1.75"	1.50"	0.63"	2.05"	5.13"	0.56"	4.13"
	1.375" 34.92	1.00" 25.4	6.88" 174.62	2.63" 66.68	133.35	76.2	73.02	15.87		44.45	38.1	15.87	52.07	130.17	14.28	104.77
HB 25 2.50" BORE	1.000" STD. 25.4	0.75" 19.05	6.75" 171.45	2.38" 60.32	5.38"	3.50"	3.00"	0.62"	1/2"	1.75"	1.50"	0.63"	2.55"	5.63"	0.56"	4.63"
	1.375" 34.92	1.00" 25.4	7.00" 177.8	2.63" 66.68												
	1.750" 44.45	1.25" 31.75	7.25" 184.15	2.88" 73.02												
HB 32 3.25" BORE	1.375" STD. 34.92	0.88" 22.22	7.88" 200.02	2.75" 69.85	6.25"	4.50"	3.50"	0.75"	3/4"	2.00"	1.75"	0.75"	3.25"	7.13"	0.69"	5.88"
	1.750" 44.45	1.13" 28.57	8.13" 206.37	3.00" 76.2												
	2.000" 50.8	1.25" 31.75	8.25" 209.55	3.13" 79.38												
HB 40 4.00" BORE	1.750" STD. 44.45	1.00" 25.4	8.50" 215.9	3.00" 76.2	6.63"	5.00"	3.75"	0.88"	3/4"	2.00"	1.75"	0.75"	3.82"	7.63"	0.69"	6.38"
	2.000" 50.8	1.13" 28.57	8.63" 219.07	3.13" 79.37												
	2.500" 63.5	1.38" 34.92	8.88" 225.42	3.38" 85.73												
HB 50 5.00" BORE	2.000" STD. 50.8	1.13" 28.57	9.13" 231.77	3.13" 79.37	7.13"	6.50"	4.25"	0.88"	3/4"	2.00"	1.75"	1.06"	4.95"	9.75"	0.94"	8.19"
	2.500" 63.5	1.38" 34.92	9.38" 238.13	3.38" 85.73												
	3.000" 76.2	1.38" 34.92	9.38" 238.13	3.38" 85.73												
	3.500" 88.9	1.38" 34.92	9.38" 238.13	3.38" 85.73												
HB 60 6.00" BORE	2.500" STD. 63.5	1.25" 31.75	10.63"	3.50"	8.38"	7.50"	4.88"	1.00"	1.00"	2.25"	2.25"	1.12"	5.73"	11.25"	1.06"	9.44"
	3.000" 76.2	1.25" 31.75														
	3.500" 88.9	1.25" 31.75														
	4.000" 101.6	1.25" 31.75														
HB 70 7.00" BORE	3.000" STD. 76.2	1.25" 31.75	11.75"	3.81"	9.50"	8.50"	5.38"	1.00"	1,1/4"	2.75"	2.75"	1.25"	6.58"	12.63"	1.19"	10.63"
	3.500" 88.9	1.25" 31.75														
	4.000" 101.6	1.25" 31.75														
	5.000" 127.0	1.25" 31.75														
HB 80 8.00" BORE	3.500" STD. 88.9	1.25" 31.75	12.75"	3.94"	10.50"	9.50"	6.13"	1.00"	1,1/2"	3.00"	3.00"	1.38"	7.50"	14.00"	1.31"	11.81"
	4.000" 101.6	1.25" 31.75														
	5.000" 127.0	1.25" 31.75														
	5.500" 139.7	1.25" 31.75														

STYLE 5
CAP
SQUARE FLANGE

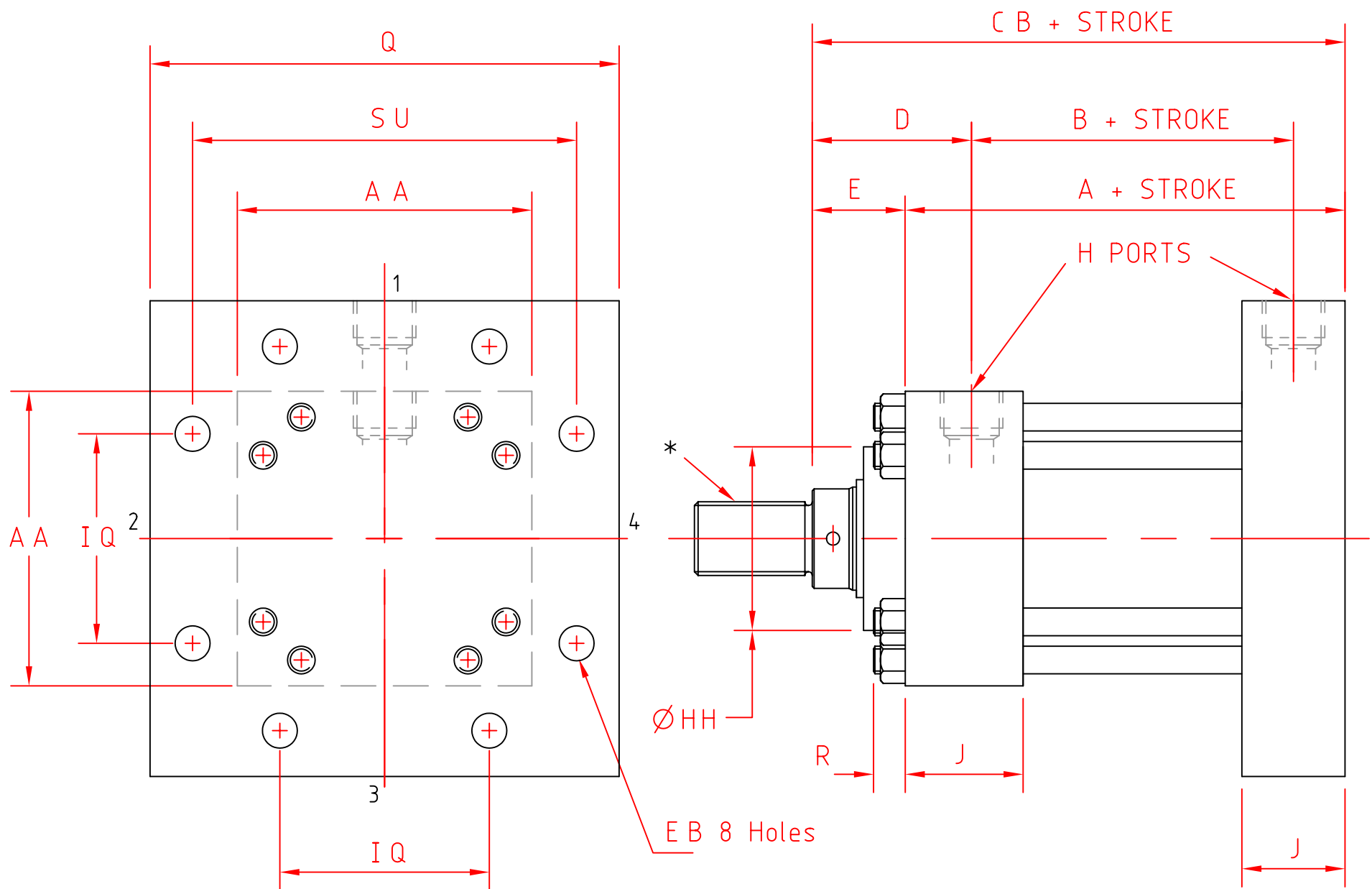

* MALE ROD END SHOWN See sheet 4A for male & female variations and dimensions

- Single Slotted CUSH. ADJ.
- Cross Slotted CUSH. Relief (Fixed)

CYLINDER SIZE	ROD DIA. E E	E	C B	D	HH Ø	A	AA	B	H	J	R	Q	SU	IQ	E B Ø
HB 100 10.00" BORE	4.50" 114.3	2.94" 74.6	15.06" 382.57	4.75" 120.65	8.25" 209.55	12.13"	12.63"	8.50"	2.00" BSPP.	3.69"	1.56"	16.63"	14.13"	9.89"	1.31"
	5.00" STD. 127.0	3.19" 80.95	15.31" 388.93	5.00" 127.0	8.75" 222.25										
	5.50" 139.7	3.19" 80.95	15.31" 388.93	5.00" 127.0	9.38" 238.13										
	7.00" 177.8	3.50" 88.9	15.63" 396.87	5.31" 134.93	10.5" 266.7										
HB 120 12.00" BORE	5.50" 139.7	3.19" 80.95	17.69" 449.25	5.44" 138.09	9.38" 238.13	14.5"	14.88"	10.00"	2.50" SAE.	4.44"	2.09"	19.75"	16.79"	11.75"	1.56"
	7.00" STD. 177.8	3.50" 88.9	18.0" 457.20	5.75" 146.05	10.5" 266.7										
	8.00" 203.2	4.00" 101.6	18.5" 469.90	6.25" 158.75	12.5" 317.5										

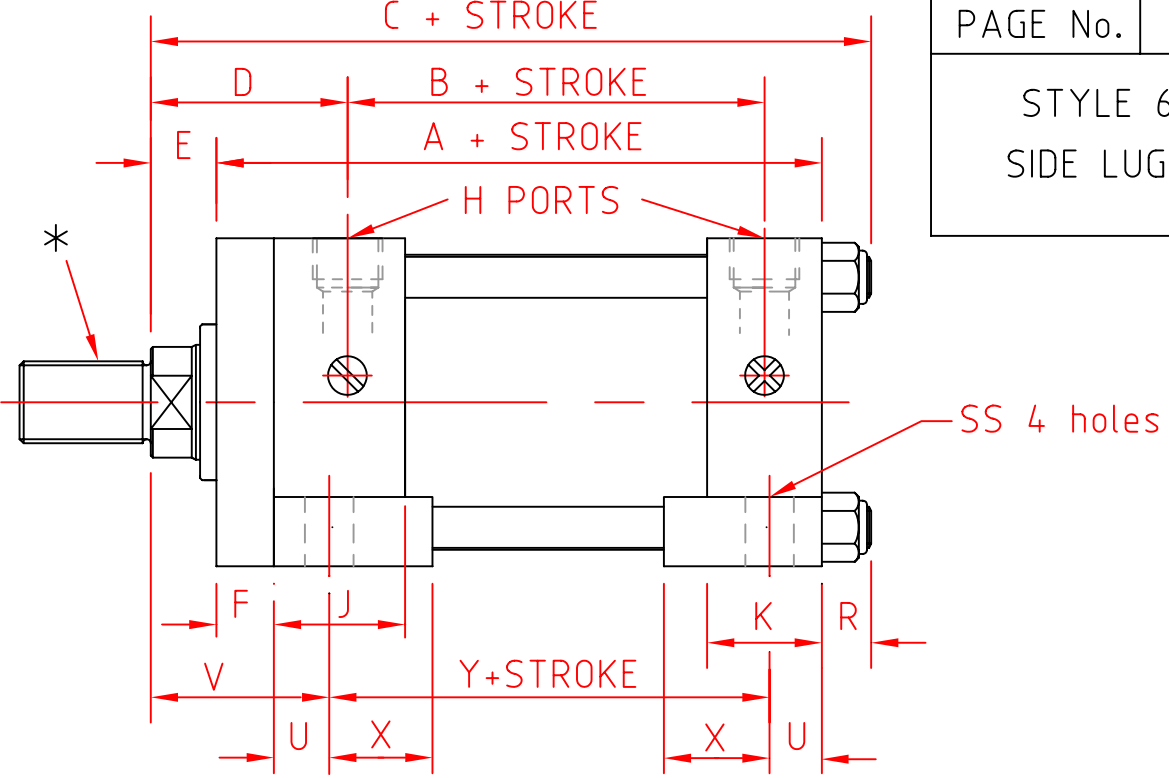
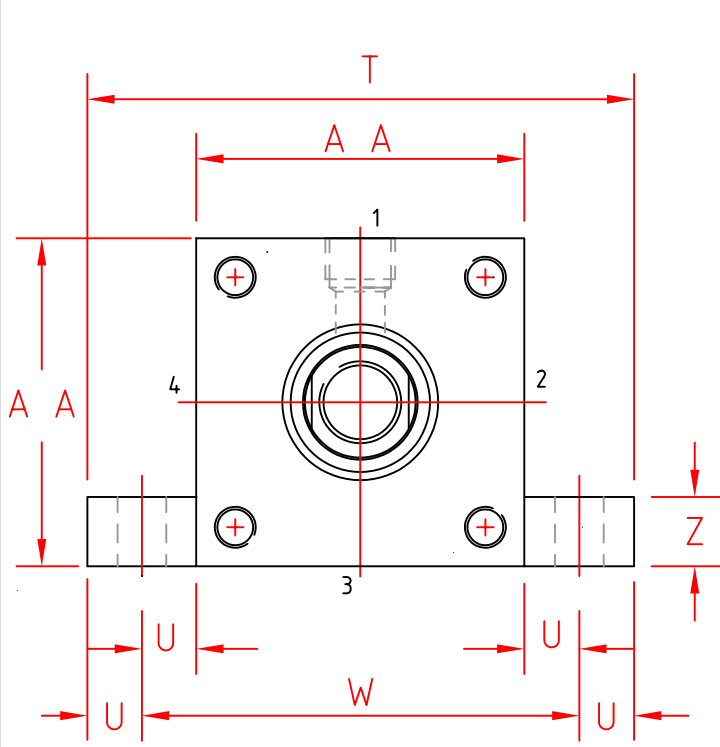

* MALE ROD END SHOWN See sheet 4 for male & female variations and dimensions

Single Slotted CUSH. ADJ.

Cross Slotted CUSH. Relief (Fixed)

CYLINDER SIZE	ROD DIA. E E	E	C	D	V	A	AA	B	F	H BSPP.	J	K	R	SS	T	U	W	X	Y	Z
HB 15 1.50" BORE	0.625" STD. 15.87	0.63" 15.87	6.13" 155.57	2.00" 50.8	1.38" 34.92	5.00"	2.50"	2.88"	0.38"	1/2"	1.75"	1.50"	0.50"	0.44"	4.00"	0.38"	3.25"	0.94"	3.88"	0.50"
	1.000" 25.4	1.00" 25.4	6.50" 165.1	2.38" 60.32	1.75" 44.45	127.0	63.5	73.02	9.52		44.45	38.1	12.7	11.11	101.6	9.52	82.55	23.81	98.42	12.7
HB 20 2.00" BORE	1.000" STD. 25.4	0.75" 19.05	6.63" 168.27	2.38" 60.32	1.88" 47.62	5.25"	3.00"	2.88"	0.62"	1/2"	1.75"	1.50"	0.63"	0.56"	5.00"	0.50"	4.00"	1.25"	3.62"	0.75"
	1.375" 34.92	1.00" 25.4	6.88" 174.63	2.63" 66.68	2.13" 53.98	133.35	76.2	73.02	15.87		44.45	38.1	15.87	14.28	127.0	12.7	101.6	31.75	92.07	19.05
HB 25 2.50" BORE	1.000" STD. 25.4	0.75" 19.05	6.75" 171.45	2.38" 60.32	2.06" 52.24	5.38"	3.50"	3.00"	0.62"	1/2"	1.75"	1.50"	0.63"	0.81"	6.25"	0.69"	4.88"	1.56"	3.38"	1.00"
	1.375" 34.92	1.00" 25.4	7.00" 177.8	2.63" 66.68	2.31" 58.73															
	1.750" 44.45	1.25" 31.75	7.25" 184.15	2.88" 73.02	2.56" 65.07															
HB 32 3.25" BORE	1.375" STD. 34.92	0.88" 22.22	7.88" 200.02	2.75" 69.85	2.31" 58.73	6.25"	4.50"	3.50"	0.75"	3/4"	2.00"	1.75"	0.75"	0.81"	7.25"	0.69"	5.88"	1.56"	4.13"	1.00"
	1.750" 44.45	1.13" 28.57	8.13" 206.5	3.00" 76.2	2.56" 65.07															
	2.000" 50.8	1.25" 31.75	8.25" 209.5	3.13" 79.38	2.69" 68.25															
HB 40 4.00" BORE	1.750" STD. 44.45	1.00" 25.4	8.38" 212.72	3.00" 76.2	2.75" 69.85	6.63"	5.00"	3.75"	0.88"	3/4"	2.00"	1.75"	0.75"	1.06"	8.50"	0.88"	6.75"	2.00"	4.00"	1.25"
	2.000" 50.8	1.13" 28.57	8.50" 215.9	3.13" 79.37	2.88" 73.02															
	2.500" 63.5	1.38" 34.92	8.75" 222.25	3.38" 85.73	3.13" 79.38															
HB 50 5.00" BORE	2.000" STD. 50.8	1.13" 28.57	9.31" 236.53	3.13" 79.37	2.88" 73.02	7.13"	6.50"	4.25"	0.88"	3/4"	2.00"	1.75"	1.06"	1.06"	10.0"	0.88"	8.25"	2.00"	4.50"	1.25"
	2.500" 63.5	1.38" 34.92	9.56" 242.88	3.38" 85.73	3.13" 79.37															
	3.000" 76.2	1.38" 34.92	9.56" 242.88	3.38" 85.73	3.13" 79.37															
	3.500" 88.9	1.38" 34.92	9.56" 242.88	3.38" 85.73	3.13" 79.37															
HB 60 6.00" BORE	2.500" STD. 63.5	1.25" 31.75	10.75"	3.50"	3.38"	8.38"	7.50"	4.88"	1.00"	1.00"	2.25"	2.25"	1.12"	1.31"	12.0"	1.13"	9.75"	2.50"	5.13"	1.50"
	3.000" 76.2	1.25" 31.75																		
	3.500" 88.9	1.25" 31.75																		
	4.000" 101.6	1.25" 31.75																		
HB 70 7.00" BORE	3.000" STD. 76.2	1.25" 31.75	12.00"	3.81"	3.63"	9.50"	8.50"	5.38"	1.00"	1,1/4"	2.75"	2.75"	1.25"	1.56"	14.0"	1.38"	11.25"	2.88"	5.75"	1.75"
	3.500" 88.9	1.25" 31.75																		
	4.000" 101.6	1.25" 31.75																		
	5.000" 127.0	1.25" 31.75																		
HB 80 8.00" BORE	3.500" STD. 88.9	1.25" 31.75	13.12"	3.94"	3.63"	10.50"	9.50"	6.13"	1.00"	1,1/2"	3.00"	3.00"	1.38"	1.56"	15.0"	1.38"	12.25"	2.88"	6.75"	1.75"
	4.000" 101.6	1.25" 31.75																		
	5.000" 127.0	1.25" 31.75																		
	5.500" 139.7	1.25" 31.75																		

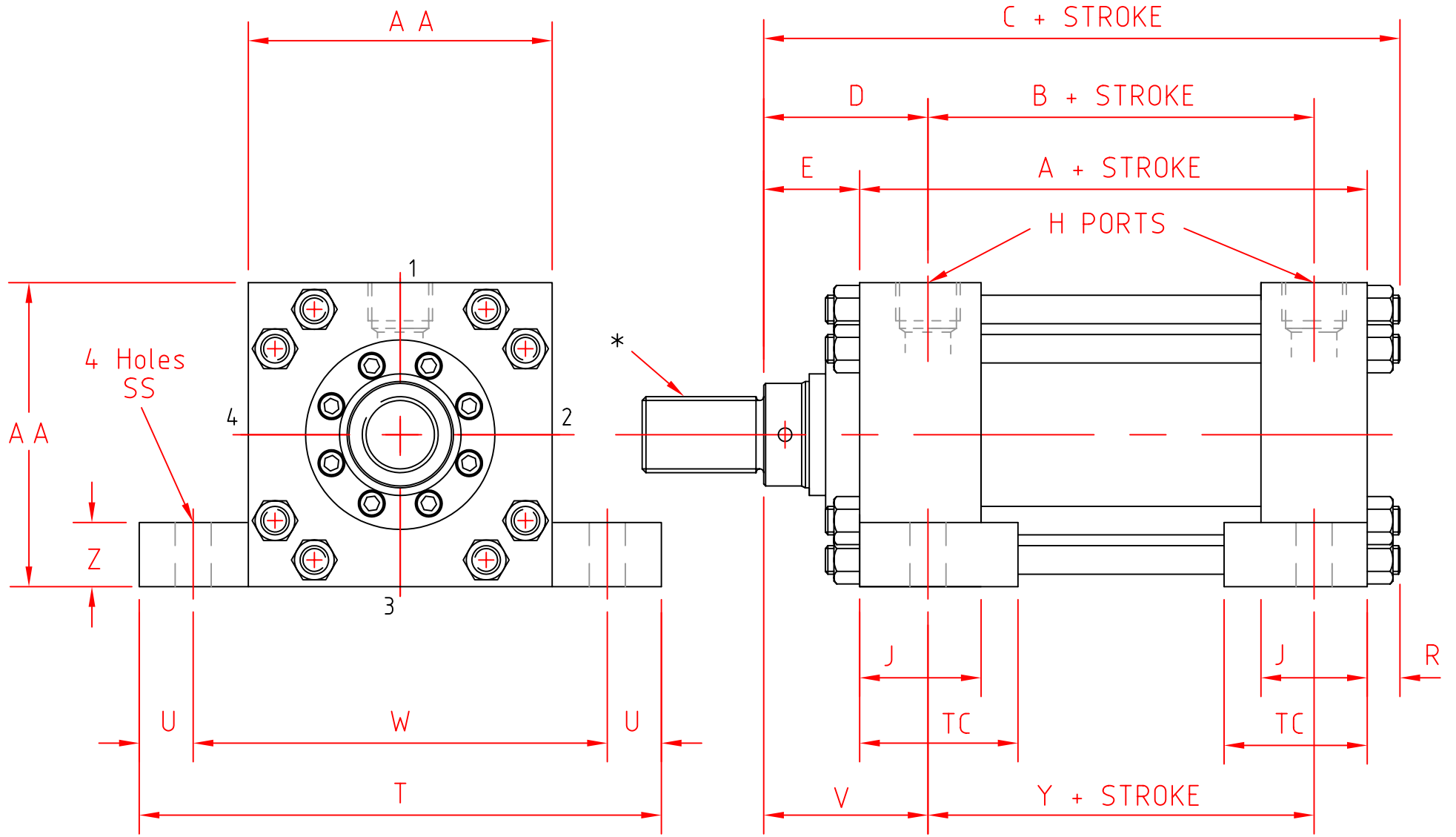

* MALE ROD END SHOWN See sheet 4A for male & female variations and dimensions

 Single Slotted CUSH. ADJ.

 Cross Slotted CUSH. Relief (Fixed)

CYLINDER SIZE	ROD DIA. E E	E	C	D	V	A	AA	B	H	J	R	SS Ø	T	U	W	TC	Y	Z
HB 100 10.00" BORE	4.50" 114.3	2.94" 74.6	16.63" 422.27	4.75" 120.65	4.56" 115.88													
	5.00" STD. 127.0	3.19" 80.95	16.88" 428.63	5.00" 127.0	4.81" 122.23	12.13"	12.63"	8.50"	2.00"	3.69"	1.56"	1.56"	19.13"	1.63"	15.88"	5.13"	8.88"	2.25"
	5.50" 139.7	3.19" 80.95	16.88" 428.63	5.00" 127.0	4.81" 122.23	307.97	320.67	215.90	BSPP.	93.65	39.68	39.68	485.7	41.27	403.22	130.17	225.42	57.15
	7.00" 177.8	3.50" 88.9	17.19" 436.56	5.31" 134.93	5.13" 130.17													
HB 120 12.00" BORE	5.50" 139.7	3.19" 80.95	19.78" 502.4	5.44" 138.09	5.19" 131.76													
	7.00" STD. 177.8	3.50" 88.9	20.09" 510.28	5.75" 146.05	5.50" 139.7	14.5"	14.88"	10.00"	2.50"	4.44"	2.09"	1.56"	22.88"	2.00"	18.88"	6.25"	10.50"	3.00"
	8.00" 203.2	4.00" 101.6	20.59" 522.98	6.25" 158.75	6.00" 152.4	368.30	377.82	254.00	SAE.	112.71	53.08	39.68	581.1	50.8	479.42	158.75	266.7	76.2

STYLE 7
CENTRE LINE
LUGS

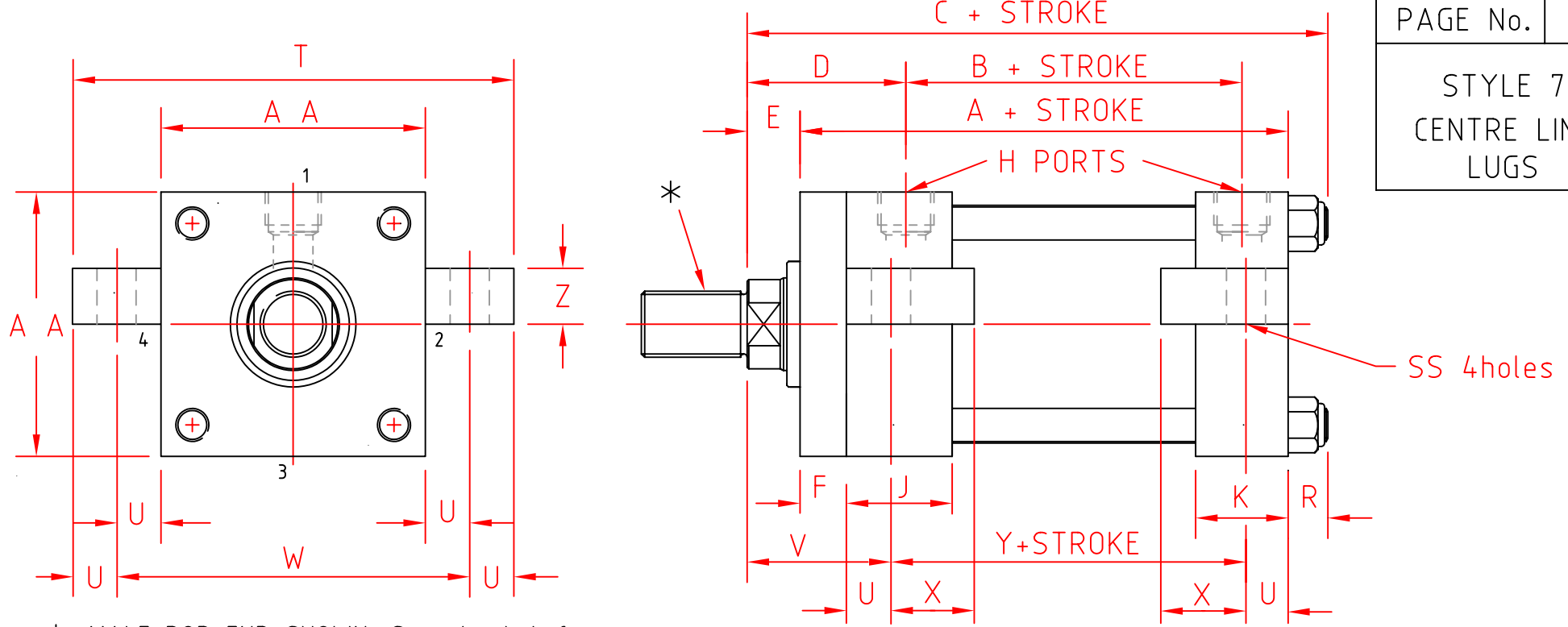

* MALE ROD END SHOWN See sheet 4 for male & female variations and dimensions

Single Slotted CUSH. ADJ.
 Cross Slotted CUSH. Relief (Fixed)

CYLINDER SIZE	ROD DIA. E E	E	C	D	V	A	AA	B	F	H BSPP.	J	K	R	SS	T	U	W	X	Y	Z
HB 15 1.50" BORE	0.625" STD. 15.87	0.63" 15.87	6.13" 155.57	2.00" 50.8	1.38" 34.92	5.00"	2.50"	2.88"	0.38"	1/2"	1.75"	1.50"	0.50"	0.44"	4.00"	0.38"	3.25"	0.94"	3.88"	0.50"
	1.000" 25.4	1.00" 25.4	6.50" 165.1	2.38" 60.32	1.75" 44.45	127.0	63.5	73.02	9.52		44.45	38.1	12.7	11.11	101.6	9.52	82.55	23.81	98.42	12.7
HB 20 2.00" BORE	1.000" STD. 25.4	0.75" 19.05	6.63" 168.27	2.38" 60.32	1.88" 47.62	5.25"	3.00"	2.88"	0.62"	1/2"	1.75"	1.50"	0.63"	0.56"	5.00"	0.50"	4.00"	1.25"	3.62"	0.75"
	1.375" 34.92	1.00" 25.4	6.88" 174.63	2.63" 66.68	2.13" 53.98	133.35	76.2	73.02	15.87		44.45	38.1	15.87	14.28	127.0	12.7	101.6	31.75	92.07	19.05
HB 25 2.50" BORE	1.000" STD. 25.4	0.75" 19.05	6.75" 171.45	2.38" 60.32	2.06" 52.24	5.38"	3.50"	3.00"	0.62"	1/2"	1.75"	1.50"	0.63"	0.81"	6.25"	0.69"	4.88"	1.56"	3.38"	1.00"
	1.375" 34.92	1.00" 25.4	7.00" 177.8	2.63" 66.68	2.31" 58.73															
	1.750" 44.45	1.25" 31.75	7.25" 184.15	2.88" 73.02	2.56" 65.07															
HB 32 3.25" BORE	1.375" STD. 34.92	0.88" 22.22	7.88" 200.02	2.75" 69.85	2.31" 58.73	6.25"	4.50"	3.50"	0.75"	3/4"	2.00"	1.75"	0.75"	0.81"	7.25"	0.69"	5.88"	1.56"	4.13"	1.00"
	1.750" 44.45	1.13" 28.57	8.13" 206.5	3.00" 76.2	2.56" 65.07															
	2.000" 50.8	1.25" 31.75	8.25" 209.5	3.13" 79.38	2.69" 68.25															
HB 40 4.00" BORE	1.750" STD. 44.45	1.00" 25.4	8.38" 212.72	3.00" 76.2	2.75" 69.85	6.63"	5.00"	3.75"	0.88"	3/4"	2.00"	1.75"	0.75"	1.06"	8.50"	0.88"	6.75"	2.00"	4.00"	1.25"
	2.000" 50.8	1.13" 28.57	8.50" 215.9	3.13" 79.37	2.88" 73.02															
	2.500" 63.5	1.38" 34.92	8.75" 222.25	3.38" 85.73	3.13" 79.38															
HB 50 5.00" BORE	2.000" STD. 50.8	1.13" 28.57	9.31" 236.53	3.13" 79.37	2.88" 73.02	7.13"	6.50"	4.25"	0.88"	3/4"	2.00"	1.75"	1.06"	1.06"	10.0"	0.88"	8.25"	2.00"	4.50"	1.25"
	2.500" 63.5	1.38" 34.92	9.56" 242.88	3.38" 85.73	3.13" 79.37															
	3.000" 76.2	1.38" 34.92	9.56" 242.88	3.38" 85.73	3.13" 79.37															
	3.500" 88.9	1.38" 34.92	9.56" 242.88	3.38" 85.73	3.13" 79.37															
HB 60 6.00" BORE	2.500" STD. 63.5	1.25" 31.75	10.75"	3.50"	3.38"	8.38"	7.50"	4.88"	1.00"	1.00"	2.25"	2.25"	1.12"	1.31"	12.0"	1.13"	9.75"	2.50"	5.13"	1.50"
	3.000" 76.2	1.25" 31.75																		
	3.500" 88.9	1.25" 31.75																		
	4.000" 101.6	1.25" 31.75																		
HB 70 7.00" BORE	3.000" STD. 76.2	1.25" 31.75	12.00"	3.81"	3.63"	9.50"	8.50"	5.38"	1.00"	1,1/4"	2.75"	2.75"	1.25"	1.56"	14.0"	1.38"	11.25	2.88"	5.75"	1.75"
	3.500" 88.9	1.25" 31.75																		
	4.000" 101.6	1.25" 31.75																		
	5.000" 127.0	1.25" 31.75																		
HB 80 8.00" BORE	3.500" STD. 88.9	1.25" 31.75	13.12"	3.94"	3.63"	10.50"	9.50"	6.13"	1.00"	1,1/2"	3.00"	3.00"	1.38"	1.56"	15.0"	1.38"	12.25"	2.88"	6.75"	1.75"
	4.000" 101.6	1.25" 31.75																		
	5.000" 127.0	1.25" 31.75																		
	5.500" 139.7	1.25" 31.75																		

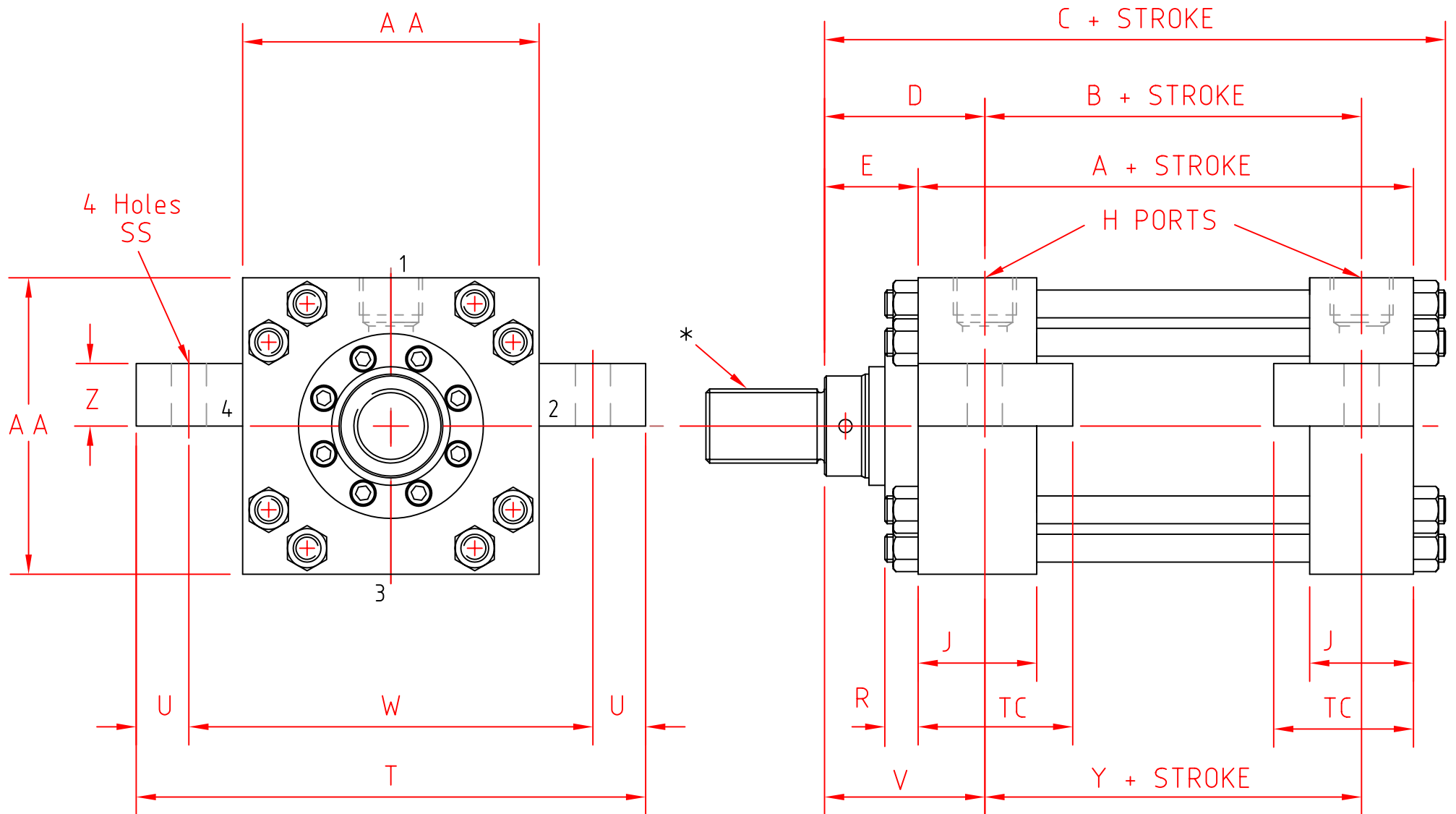

* MALE ROD END SHOWN See sheet 4A for male & female variations and dimensions

⊗ Single Slotted CUSH. ADJ.

⊗ Cross Slotted CUSH. Relief (Fixed)

CYLINDER SIZE	ROD DIA. E E	E	C	D	V	A	AA	B	H	J	R	SS Ø	T	U	W	TC	Y	Z
HB 100 10.00" BORE	4.50" 114.3	2.94" 74.6	16.63" 422.27	4.75" 120.65	4.56" 115.88	12.13" 307.97	12.63" 320.67	8.50" 215.90	2.00" BSPP.	3.69" 93.65	1.56" 39.68	1.56" 39.68	19.13" 485.7	1.63" 41.27	15.88" 403.22	5.13" 130.17	8.88" 225.42	2.25" 57.15
	5.00" STD. 127.0	3.19" 80.95	16.88" 428.63	5.00" 127.0	4.81" 122.23													
	5.50" 139.7	3.19" 80.95	16.88" 428.63	5.00" 127.0	4.81" 122.23													
	7.00" 177.8	3.50" 88.9	17.19" 436.56	5.31" 134.93	5.13" 130.17													
HB 120 12.00" BORE	5.50" 139.7	3.19" 80.95	19.78" 502.4	5.44" 138.09	5.19" 131.76	14.5" 368.30	14.88" 377.82	10.00" 254.00	2.50" SAE.	4.44" 112.71	2.09" 53.08	1.56" 39.68	22.88" 581.1	2.00" 50.8	18.88" 479.42	6.25" 158.75	10.50" 266.7	3.00" 76.2
	7.00" STD. 177.8	3.50" 88.9	20.09" 510.28	5.75" 146.05	5.50" 139.7													
	8.00" 203.2	4.00" 101.6	20.59" 522.98	6.25" 158.75	6.00" 152.4													

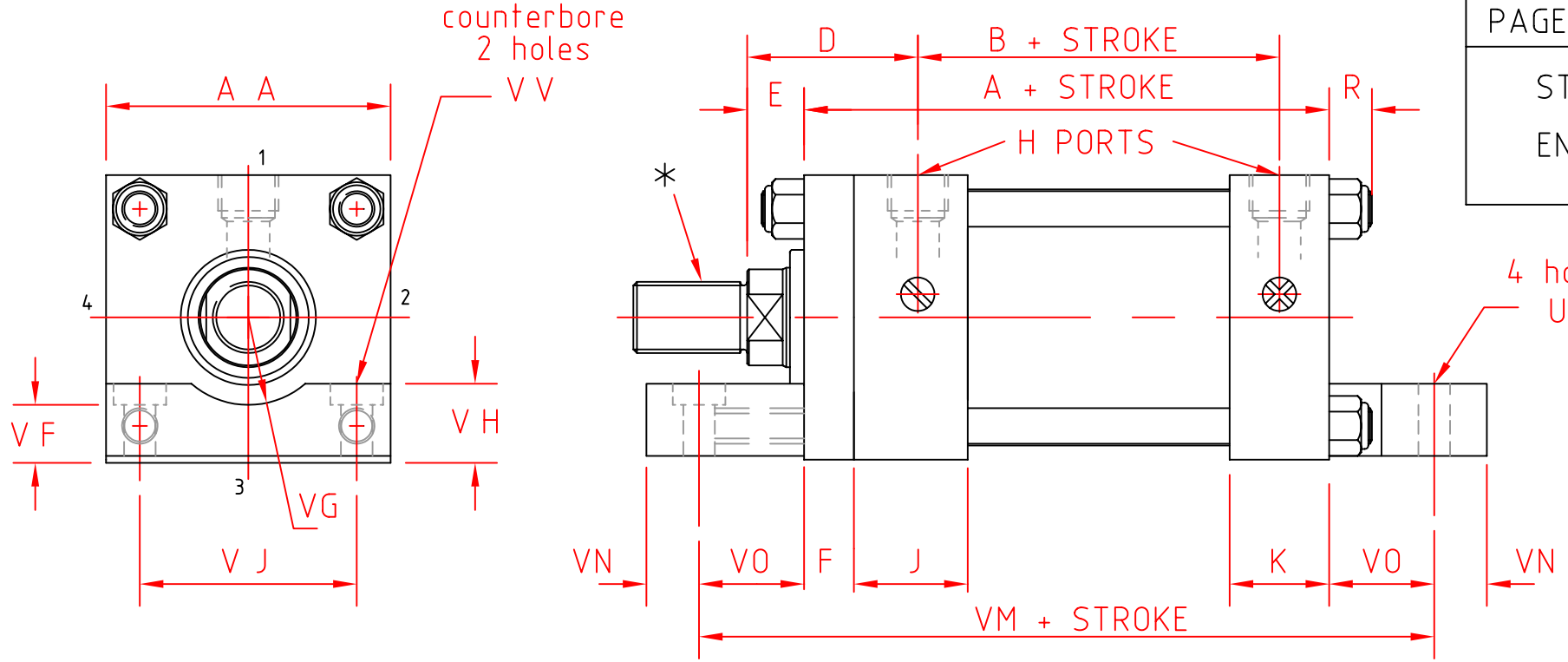

* MALE ROD END SHOWN See sheet 4 for male & female variations and dimensions

⊗ Single Slotted CUSH. ADJ. ⊗ Cross Slotted CUSH. Relief (Fixed)

CYLINDER SIZE	ROD DIA. E E	E	D	A	AA	B	F	H BSPP.	J	K	R	VO	VG	UU	VJ	VM	VF	VH	VN	VV															
HB 15 1.50" BORE	0.625" STD. 15.87	0.63" 15.87	2.00" 50.8	5.00"	2.50"	2.88"	0.38"	1/2"	1.75"	1.50"	0.50"	0.88"	0.84"	0.44"	1.63"	6.75"	0.75"	0.88"	0.38"	0.63"															
	1.000" 25.4	1.00" 25.4	2.38" 60.32	127.0	63.5	73.02	9.52	1/2"	44.45	38.1	12.7	22.22	21.33	11.11	41.27	171.45	19.05	22.22	9.52	15.87															
HB 20 2.00" BORE	1.000" STD. 25.4	0.75" 19.05	2.38" 60.32	5.25"	3.00"	2.88"	0.62"	1/2"	1.75"	1.50"	0.63"	0.94"	1.09"	0.56"	2.05"	7.13"	0.81"	1.00"	0.50"	0.81"															
	1.375" 34.92	1.00" 25.4	2.63" 66.68	133.35	76.2	73.02	15.87	1/2"	44.45	38.1	15.87	23.81	28.57	14.28	52.38	180.97	20.63	25.4	12.7	20.63															
HB 25 2.50" BORE	1.000" STD. 25.4	0.75" 19.05	2.38" 60.32	5.38"	3.50"	3.00"	0.62"	1/2"	1.75"	1.50"	0.63"	0.94"	1.34"	0.56"	2.55"	7.25"	N/A	1.00"	0.50"	N/A															
	1.375" 34.92	1.00" 25.4	2.63" 66.68																		136.52	88.9	76.2	15.87	44.45	38.1	15.87	23.81	33.33	14.28	64.00	184.15	25.4	12.7	
	1.750" 44.45	1.25" 31.75	2.88" 73.02																		88.9	76.2	15.87	44.45	38.1	15.87	23.81	33.33	14.28	64.00	184.15	25.4	12.7		
HB 32 3.25" BORE	1.375" STD. 34.92	0.88" 22.22	2.75" 69.85	6.25"	4.50"	3.50"	0.75"	3/4"	2.00"	1.75"	0.75"	1.13"	1.50"	0.69"	3.25"	8.50"	N/A	1.25"	0.63"	N/A															
	1.750" 44.45	1.13" 28.57	3.00" 76.2																		158.75	114.3	88.9	19.05	50.8	44.45	19.05	28.57	38.1	17.46	82.55	215.90	31.75	15.87	
	2.000" 50.8	1.25" 31.75	3.13" 79.38																		158.75	114.3	88.9	19.05	50.8	44.45	19.05	28.57	38.1	17.46	82.55	215.90	31.75	15.87	
HB 40 4.00" BORE	1.750" STD. 44.45	1.00" 25.4	3.00" 76.2	6.63"	5.00"	3.75"	0.88"	3/4"	2.00"	1.75"	0.75"	1.13"	1.81"	0.69"	3.82"	8.88"	N/A	1.25"	0.63"	N/A															
	2.000" 50.8	1.13" 28.57	3.13" 79.37																		168.27	127.0	95.25	22.22	50.8	44.45	19.05	28.57	46.03	17.46	96.83	225.42	31.75	15.87	
	2.500" 63.5	1.38" 34.92	3.38" 85.73																		168.27	127.0	95.25	22.22	50.8	44.45	19.05	28.57	46.03	17.46	96.83	225.42	31.75	15.87	
HB 50 5.00" BORE	2.000" STD. 50.8	1.13" 28.57	3.13" 79.37	7.13"	6.50"	4.25"	0.88"	3/4"	2.00"	1.75"	1.06"	1.50"	2.31"	0.94"	4.95"	10.13"	N/A	1.50"	0.75"	N/A															
	2.500" 63.5	1.38" 34.92	3.38" 85.73																		180.97	165.1	107.95	22.22	50.8	44.45	26.98	38.1	58.73	23.81	125.41	257.13	38.1	19.05	
	3.000" 76.2	1.38" 34.92	3.38" 85.73																		180.97	165.1	107.95	22.22	50.8	44.45	26.98	38.1	58.73	23.81	125.41	257.13	38.1	19.05	
	3.500" 88.9	1.38" 34.92	3.38" 85.73																		180.97	165.1	107.95	22.22	50.8	44.45	26.98	38.1	58.73	23.81	125.41	257.13	38.1	19.05	
HB 60 6.00" BORE	2.500" STD. 63.5	1.25" 31.75	3.50"	8.38"	7.50"	4.88"	1.00"	1.00"	2.25"	2.25"	1.12"	1.69"	2.56"	1.06"	5.73"	11.75"	N/A	1.75"	0.88"	N/A															
	3.000" 76.2	1.25" 31.75																			88.9	212.72	190.50	132.82	25.4	57.15	57.15	28.57	42.86	64.00	26.98	146.05	298.45	44.45	22.22
	3.500" 88.9	1.25" 31.75																			88.9	212.72	190.50	132.82	25.4	57.15	57.15	28.57	42.86	64.00	26.98	146.05	298.45	44.45	22.22
	4.000" 101.6	1.25" 31.75																			88.9	212.72	190.50	132.82	25.4	57.15	57.15	28.57	42.86	64.00	26.98	146.05	298.45	44.45	22.22
HB 70 7.00" BORE	3.000" STD. 76.2	1.25" 31.75	3.81"	9.50"	8.50"	5.38"	1.00"	1,1/4"	2.75"	2.75"	1.25"	1.81"	3.13"	1.19"	6.58"	13.13"	N/A	2.00"	1.00"	N/A															
	3.500" 88.9	1.25" 31.75																			96.83	241.3	215.9	136.52	25.4	69.85	69.85	31.75	46.03	79.37	30.16	166.68	333.37	50.8	25.4
	4.000" 101.6	1.25" 31.75																			96.83	241.3	215.9	136.52	25.4	69.85	69.85	31.75	46.03	79.37	30.16	166.68	333.37	50.8	25.4
	5.000" 127.0	1.25" 31.75																			96.83	241.3	215.9	136.52	25.4	69.85	69.85	31.75	46.03	79.37	30.16	166.68	333.37	50.8	25.4
HB 80 8.00" BORE	3.500" STD. 88.9	1.25" 31.75	3.94"	10.50"	9.50"	6.13"	1.00"	1,1/2"	3.00"	3.00"	1.38"	2.00"	3.38"	1.31"	7.50"	14.50"	N/A	2.00"	1.13"	N/A															
	4.000" 101.6	1.25" 31.75																			100.0	266.7	241.3	155.57	25.4	76.2	76.2	34.92	50.8	85.72	33.33	190.5	368.3	50.8	28.57
	5.000" 127.0	1.25" 31.75																			100.0	266.7	241.3	155.57	25.4	76.2	76.2	34.92	50.8	85.72	33.33	190.5	368.3	50.8	28.57
	5.500" 139.7	1.25" 31.75																			100.0	266.7	241.3	155.57	25.4	76.2	76.2	34.92	50.8	85.72	33.33	190.5	368.3	50.8	28.57

STYLE 11
HEAD
TRUNNION

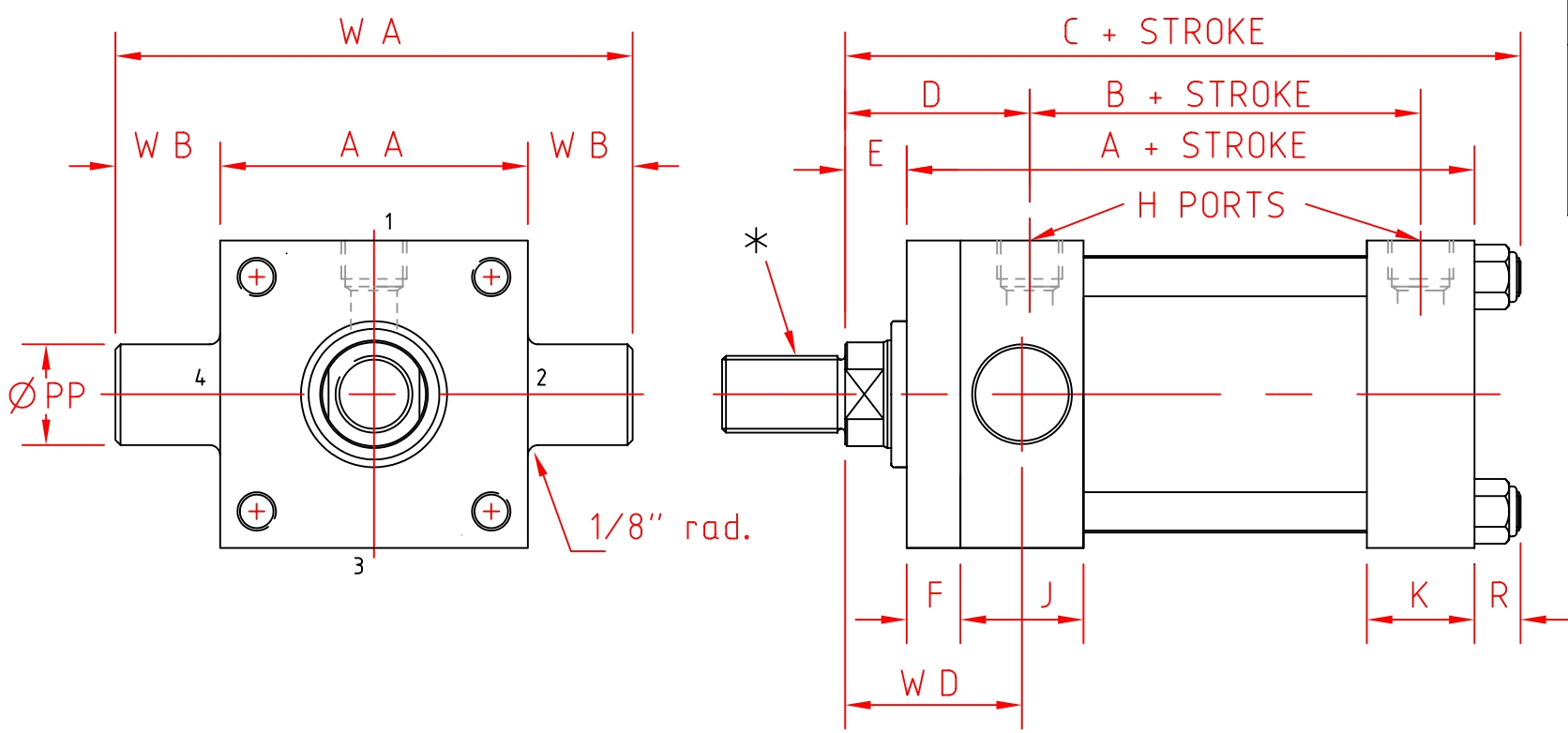

* MALE ROD END SHOWN See sheet 4 for male & female variations and dimensions

⊗ Single Slotted CUSH. ADJ.

⊗ Cross Slotted CUSH. Relief (Fixed)

CYLINDER SIZE	ROD DIA. E E	E	C	D	WD	A	AA	B	F	H BSPP.	J	K	R	WA	WB	PP
HB 15 1.50" BORE	0.625" STD. 15.87	0.63" 15.87	6.13" 155.57	2.00" 50.8	1.88" 47.62	5.00"	2.50"	2.88"	0.38"	1/2"	1.75"	1.50"	0.50"	4.50"	1.00"	1.000"
	1.000" 25.4	1.00" 25.4	6.50" 165.1	2.38" 60.32	2.25" 57.15	127.0	63.5	73.02	9.52		44.45	38.1	12.7	114.3	25.4	25.40
HB 20 2.00" BORE	1.000" STD. 25.4	0.75" 19.05	6.63" 168.27	2.38" 60.32	2.25" 57.15	5.25"	3.00"	2.88"	0.62"	1/2"	1.75"	1.50"	0.63"	5.75"	1.38"	1.375"
	1.375" 34.92	1.00" 25.4	6.88" 174.63	2.63" 66.68	2.50" 63.5	133.35	76.2	73.02	15.87		44.45	38.1	15.87	146.05	34.92	34.925
HB 25 2.50" BORE	1.000" STD. 25.4	0.75" 19.05	6.75" 171.45	2.38" 60.32	2.25" 57.15	5.38" 136.52	3.50" 88.9	3.00" 76.2	0.62" 15.87	1/2"	1.75" 44.45	1.50" 38.1	0.63" 15.87	6.25" 158.75	1.38" 34.92	1.375" 34.925
	1.375" 34.92	1.00" 25.4	7.00" 177.8	2.63" 66.68	2.50" 63.5											
	1.750" 44.45	1.25" 31.75	7.25" 184.15	2.88" 73.02	2.75" 69.85											
HB 32 3.25" BORE	1.375" STD. 34.92	0.88" 22.22	7.88" 200.02	2.75" 69.85	2.63" 66.68	6.25" 158.75	4.50" 114.3	3.50" 88.9	0.75" 19.05	3/4"	2.00" 50.8	1.75" 44.45	0.75" 19.05	8.00" 203.2	1.75" 44.45	1.750" 44.45
	1.750" 44.45	1.13" 28.57	8.13" 206.5	3.00" 76.2	2.88" 73.02											
	2.000" 50.8	1.25" 31.75	8.25" 209.5	3.13" 79.38	3.00" 76.2											
HB 40 4.00" BORE	1.750" STD. 44.45	1.00" 25.4	8.38" 212.72	3.00" 76.2	2.88" 73.02	6.63" 168.27	5.00" 127.0	3.75" 95.25	0.88" 22.22	3/4"	2.00" 50.8	1.75" 44.45	0.75" 19.05	8.50" 215.90	1.75" 44.45	1.750" 44.45
	2.000" 50.8	1.13" 28.57	8.50" 215.9	3.13" 79.37	3.00" 76.2											
	2.500" 63.5	1.38" 34.92	8.75" 222.25	3.38" 85.73	3.25" 82.55											
HB 50 5.00" BORE	2.000" STD. 50.8	1.13" 28.57	9.31" 236.53	3.13" 79.37	3.00" 76.2	7.13" 180.97	6.50" 165.1	4.25" 107.95	0.88" 22.22	3/4"	2.00" 50.8	1.75" 44.45	1.06" 26.98	10.00" 254.0	1.75" 44.45	1.750" 44.45
	2.500" 63.5	1.38" 34.92	9.56" 242.88	3.38" 85.73	3.25" 82.55											
	3.000" 76.2	1.38" 34.92	9.56" 242.88	3.38" 85.73	3.25" 82.55											
	3.500" 88.9	1.38" 34.92	9.56" 242.88	3.38" 85.73	3.25" 82.55											
HB 60 6.00" BORE	2.500" STD. 63.5	1.25" 31.75	10.75" 273.05	3.50" 88.9	3.38" 85.73	8.38" 212.72	7.50" 190.50	4.88" 132.82	1.00" 25.4	1.00"	2.25" 57.15	2.25" 57.15	1.12" 28.57	11.50" 292.10	2.00" 50.8	2.000" 50.8
	3.000" 76.2	1.25" 31.75														
	3.500" 88.9	1.25" 31.75														
	4.000" 101.6	1.25" 31.75														
HB 70 7.00" BORE	3.000" STD. 76.2	1.25" 31.75	12.00" 304.8	3.81" 96.83	3.63" 92.07	9.50" 241.3	8.50" 215.9	5.38" 136.52	1.00" 25.4	1,1/4"	2.75" 69.85	2.75" 69.85	1.25" 31.75	13.50" 342.9	2.50" 63.5	2.500" 63.50
	3.500" 88.9	1.25" 31.75														
	4.000" 101.6	1.25" 31.75														
	5.000" 127.0	1.25" 31.75														
HB 80 8.00" BORE	3.500" STD. 88.9	1.25" 31.75	13.12" 333.37	3.94" 100.0	3.75" 95.25	10.50" 266.7	9.50" 241.3	6.13" 155.57	1.00" 25.4	1,1/2"	3.00" 76.2	3.00" 76.2	1.38" 34.92	15.50" 393.70	3.00" 76.2	3.000" 76.20
	4.000" 101.6	1.25" 31.75														
	5.000" 127.0	1.25" 31.75														
	5.500" 139.7	1.25" 31.75														

STYLE 11
HEAD
TRUNNION

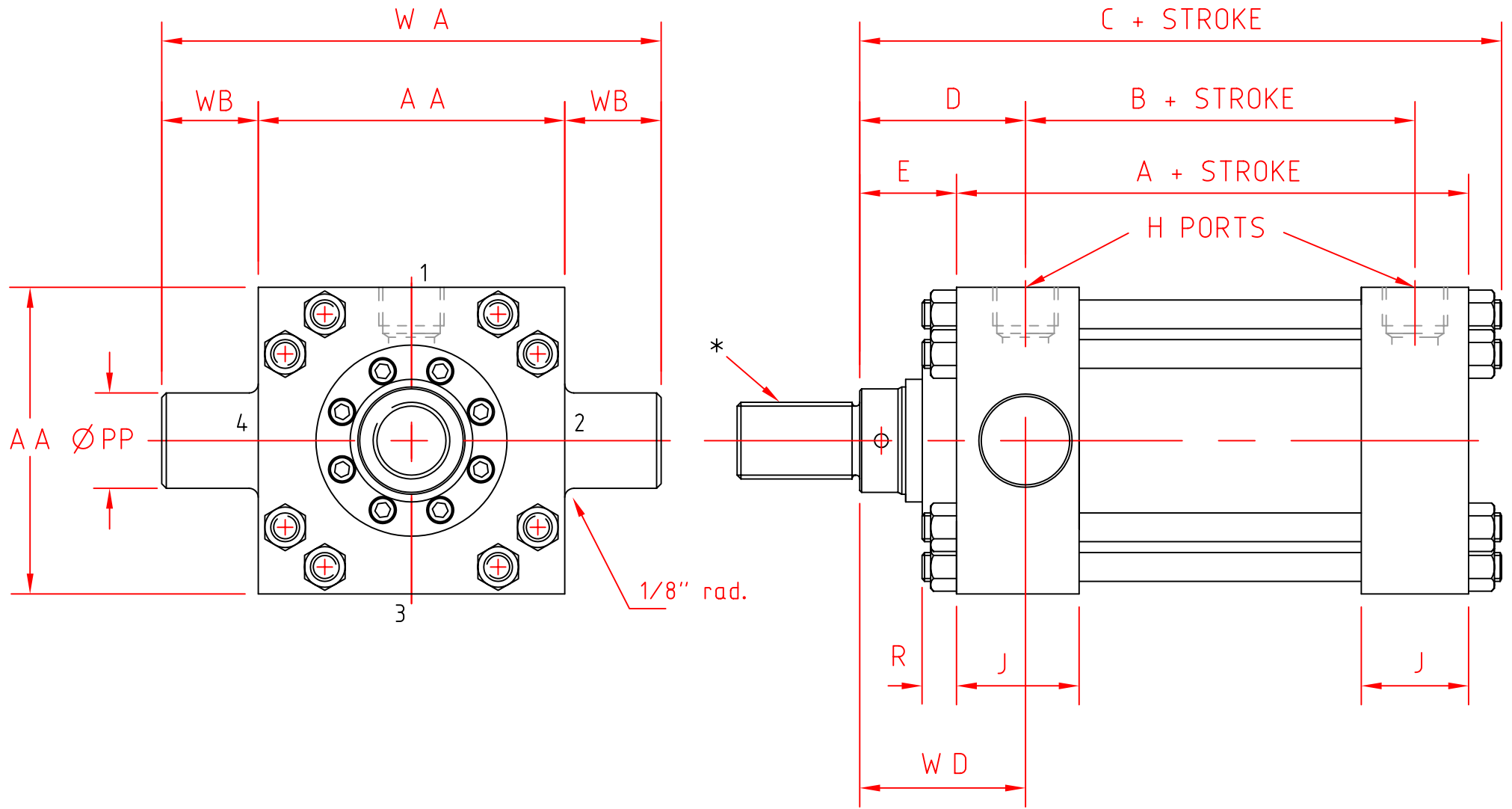

* MALE ROD END SHOWN See sheet 4A for male & female variations and dimensions

Single Slotted CUSH. ADJ.

Cross Slotted CUSH. Relief (Fixed)

CYLINDER SIZE	ROD DIA. E E	E	C	D	WD	A	AA	B	H	J	R	WA	WB	PP \varnothing
HB 100 10.00" BORE	4.50" 114.3	2.94" 74.6	16.63" 422.27	4.75" 120.65	4.75" 120.65									
	5.00" STD. 127.0	3.19" 80.95	16.88" 428.63	5.00" 127.0	5.00" 127.0	12.13"	12.63"	8.50"	2.00"	3.69"	1.56"	19.63"	3.50"	3.500"
	5.50" 139.7	3.19" 80.95	16.88" 428.63	5.00" 127.0	5.00" 127.0	307.97	320.67	215.90	BSPP.	93.65	39.68	498.47	88.9	88.90
	7.00" 177.8	3.50" 88.9	17.19" 436.56	5.31" 134.93	5.31" 134.93									
HB 120 12.00" BORE	5.50" 139.7	3.19" 80.95	19.78" 502.4	5.44" 138.09	5.38" 136.52									
	7.00" STD. 177.8	3.50" 88.9	20.09" 510.28	5.75" 146.05	5.69" 144.46	14.5"	14.88"	10.00"	2.50"	4.44"	2.09"	22.88"	4.00"	4.000"
	8.00" 203.2	4.00" 101.6	20.59" 522.98	6.25" 158.75	6.19" 157.16	368.30	377.82	254.00	SAE.	112.71	53.08	581.15	101.6	101.60

STYLE 12
CAP
TRUNNION

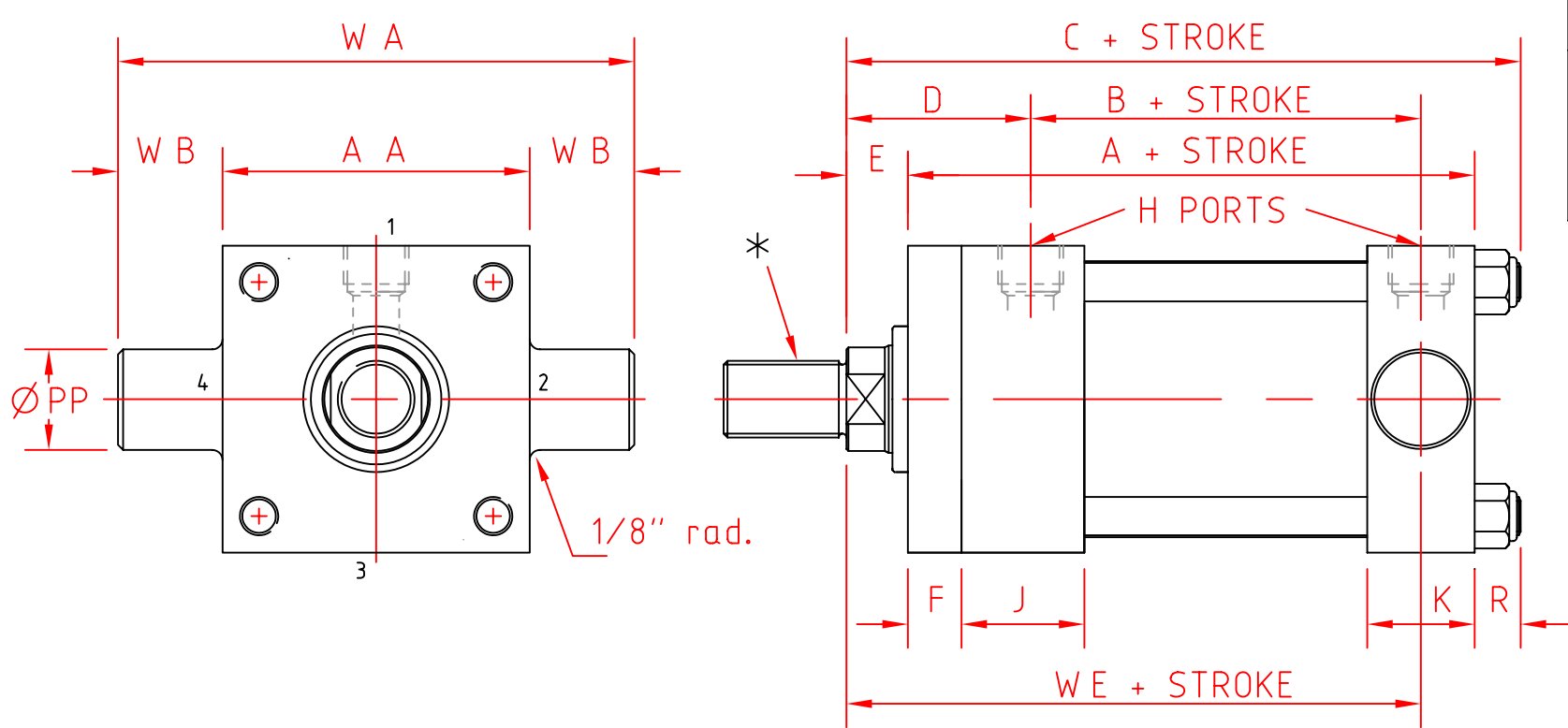

* MALE ROD END SHOWN See sheet 4 for male & female variations and dimensions

⊗ Single Slotted CUSH. ADJ.

⊗ Cross Slotted CUSH. Relief (Fixed)

CYLINDER SIZE	ROD DIA. E E	E	C	D	WE	A	AA	B	F	H BSPP.	J	K	R	WA	WB	PP
HB 15 1.50" BORE	0.625" STD. 15.87	0.63" 15.87	6.13" 155.57	2.00" 50.8	4.88" 123.82	5.00"	2.50"	2.88"	0.38"	1/2"	1.75"	1.50"	0.50"	4.50"	1.00"	1.000"
	1.000" 25.4	1.00" 25.4	6.50" 165.1	2.38" 60.32	5.25" 133.35	127.0	63.5	73.02	9.52		44.45	38.1	12.7	114.3	25.4	25.40
HB 20 2.00" BORE	1.000" STD. 25.4	0.75" 19.05	6.63" 168.27	2.38" 60.32	5.25" 133.35	5.25"	3.00"	2.88"	0.62"	1/2"	1.75"	1.50"	0.63"	5.75"	1.38"	1.375"
	1.375" 34.92	1.00" 25.4	6.88" 174.63	2.63" 66.68	5.50" 139.7	133.35	76.2	73.02	15.87		44.45	38.1	15.87	146.05	34.92	34.925
HB 25 2.50" BORE	1.000" STD. 25.4	0.75" 19.05	6.75" 171.45	2.38" 60.32	5.38" 136.52	5.38"	3.50"	3.00"	0.62"	1/2"	1.75"	1.50"	0.63"	6.25"	1.38"	1.375"
	1.375" 34.92	1.00" 25.4	7.00" 177.8	2.63" 66.68	5.63" 142.87											
	1.750" 44.45	1.25" 31.75	7.25" 184.15	2.88" 73.02	5.88" 149.23											
HB 32 3.25" BORE	1.375" STD. 34.92	0.88" 22.22	7.88" 200.02	2.75" 69.85	6.25" 158.75	6.25"	4.50"	3.50"	0.75"	3/4"	2.00"	1.75"	0.75"	8.00"	1.75"	1.750"
	1.750" 44.45	1.13" 28.57	8.13" 206.5	3.00" 76.2	6.50" 165.1											
	2.000" 50.8	1.25" 31.75	8.25" 209.5	3.13" 79.38	6.63" 168.28											
HB 40 4.00" BORE	1.750" STD. 44.45	1.00" 25.4	8.38" 212.72	3.00" 76.2	6.75" 171.45	6.63"	5.00"	3.75"	0.88"	3/4"	2.00"	1.75"	0.75"	8.50"	1.75"	1.750"
	2.000" 50.8	1.13" 28.57	8.50" 215.9	3.13" 79.37	6.88" 174.63											
	2.500" 63.5	1.38" 34.92	8.75" 222.25	3.38" 85.73	7.13" 180.97											
HB 50 5.00" BORE	2.000" STD. 50.8	1.13" 28.57	9.31" 236.53	3.13" 79.37	7.38" 187.32	7.13"	6.50"	4.25"	0.88"	3/4"	2.00"	1.75"	1.06"	10.00"	1.75"	1.750"
	2.500" 63.5	1.38" 34.92	9.56" 242.88	3.38" 85.73	7.63" 193.68											
	3.000" 76.2	1.38" 34.92	9.56" 242.88	3.38" 85.73	7.63" 193.68											
	3.500" 88.9	1.38" 34.92	9.56" 242.88	3.38" 85.73	7.63" 193.68											
HB 60 6.00" BORE	2.500" STD. 63.5	1.25" 31.75	10.75"	3.50"	8.38"	8.38"	7.50"	4.88"	1.00"	1.00"	2.25"	2.25"	1.12"	11.50"	2.00"	2.000"
	3.000" 76.2	1.25" 31.75														
	3.500" 88.9	1.25" 31.75														
	4.000" 101.6	1.25" 31.75														
HB 70 7.00" BORE	3.000" STD. 76.2	1.25" 31.75	12.00"	3.81"	9.38"	9.50"	8.50"	5.38"	1.00"	1,1/4"	2.75"	2.75"	1.25"	13.50"	2.50"	2.500"
	3.500" 88.9	1.25" 31.75														
	4.000" 101.6	1.25" 31.75														
	5.000" 127.0	1.25" 31.75														
HB 80 8.00" BORE	3.500" STD. 88.9	1.25" 31.75	13.12"	3.94"	10.25"	10.50"	9.50"	6.13"	1.00"	1,1/2"	3.00"	3.00"	1.38"	15.50"	3.00"	3.000"
	4.000" 101.6	1.25" 31.75														
	5.000" 127.0	1.25" 31.75														
	5.500" 139.7	1.25" 31.75														

STYLE 12
CAP
TRUNNION

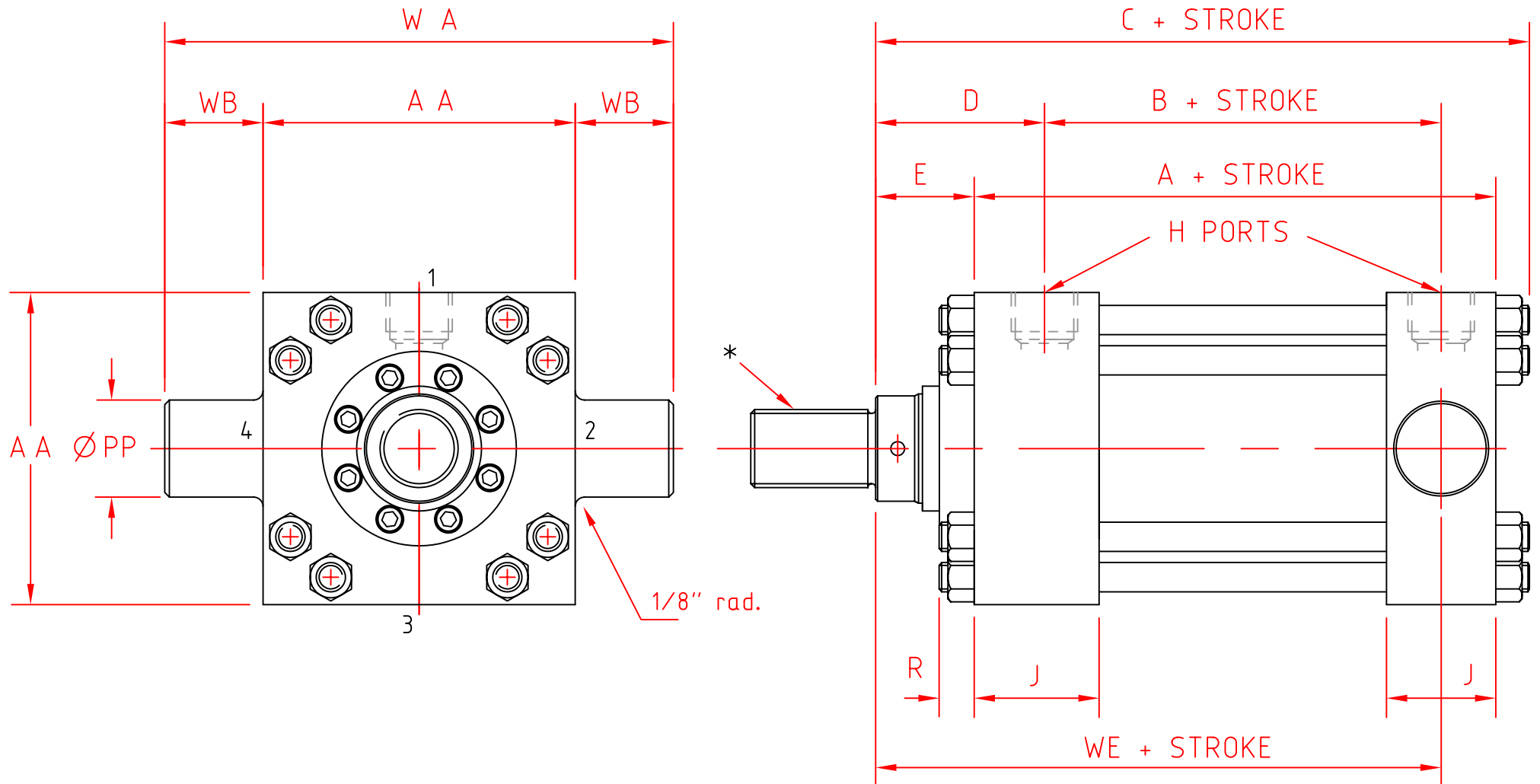

* MALE ROD END SHOWN See sheet 4A for male & female variations and dimensions

Single Slotted CUSH. ADJ.

Cross Slotted CUSH. Relief (Fixed)

CYLINDER SIZE	ROD DIA. E E	E	C	D	WE	A	AA	B	H	J	R	WA	WB	PP Ø
HB 100 10.00" BORE	4.50" 114.3	2.94" 74.6	16.63" 422.27	4.75" 120.65	13.38" 339.72									
	5.00" STD. 127.0	3.19" 80.95	16.88" 428.63	5.00" 127.0	13.63" 346.07	12.13"	12.63"	8.50"	2.00"	3.69"	1.56"	19.63"	3.50"	3.500"
	5.50" 139.7	3.19" 80.95	16.88" 428.63	5.00" 127.0	13.63" 346.07	307.97	320.67	215.90	BSPP.	93.65	39.68	498.47	88.9	88.90
	7.00" 177.8	3.50" 88.9	17.19" 436.56	5.31" 134.93	13.94" 354.01									
HB 120 12.00" BORE	5.50" 139.7	3.19" 80.95	19.78" 502.4	5.44" 138.09	15.50" 393.7									
	7.00" STD. 177.8	3.50" 88.9	20.09" 510.28	5.75" 146.05	15.81" 401.63	14.5"	14.88"	10.00"	2.50"	4.44"	2.09"	22.88"	4.00"	4.000"
	8.00" 203.2	4.00" 101.6	20.59" 522.98	6.25" 158.75	16.31" 414.33	368.30	377.82	254.00	SAE.	112.71	53.08	581.15	101.6	101.60

STYLE 13
INTERMEDIATE
TRUNNION

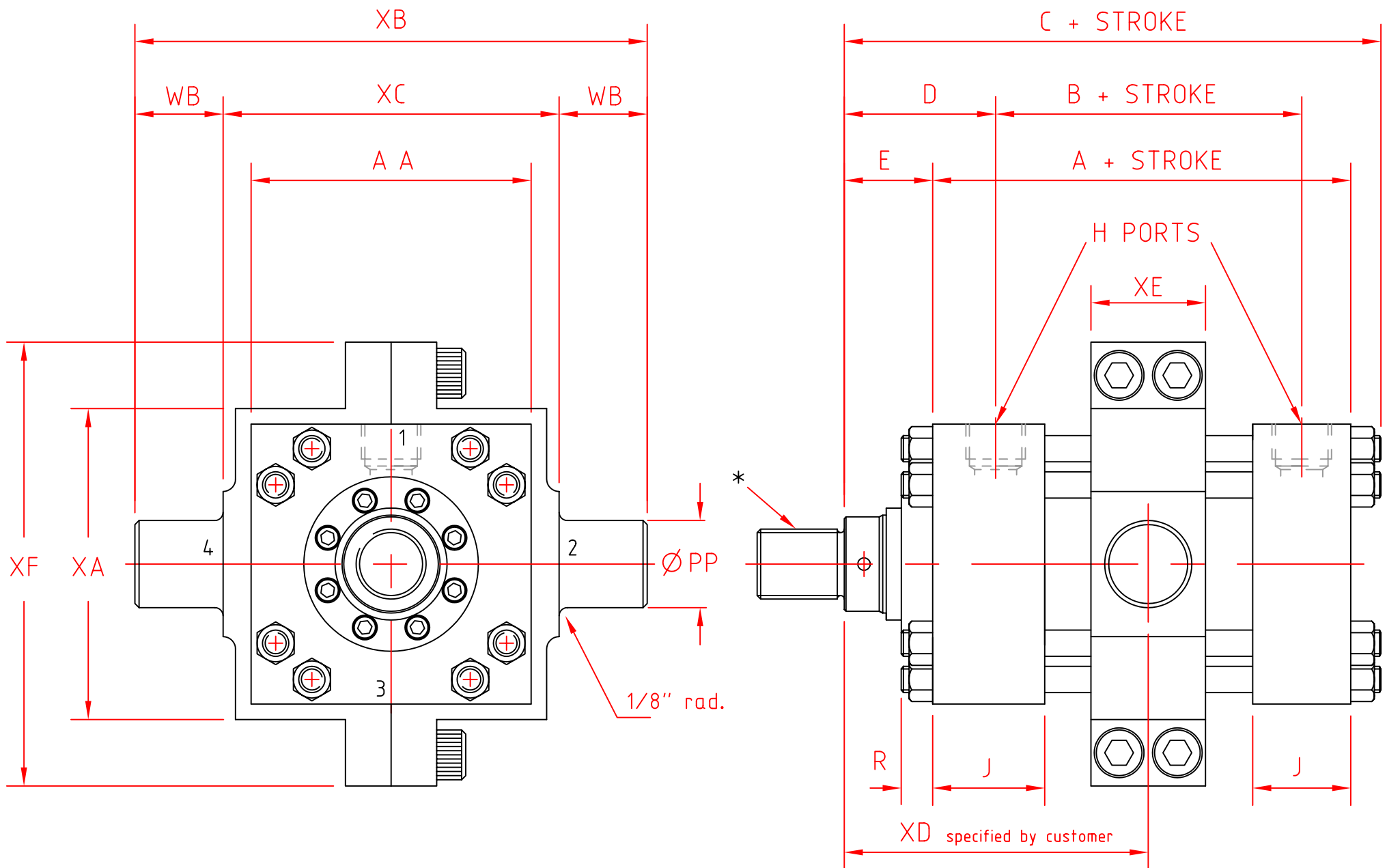

* MALE ROD END SHOWN See sheet 4A for male & female variations and dimensions

 Single Slotted CUSH. ADJ.

 Cross Slotted CUSH. Relief (Fixed)

CYLINDER SIZE	ROD DIA. E E	E	C	D	XD (min.)	A	AA	B	H	J	R	XA	XB	XC	WB	PP \varnothing	XE	XF
HB 100 10.00" BORE	4.50" 114.3	2.94" 74.6	16.63" 422.27	4.75" 120.65	9.06" 230.18	12.13"	12.63"	8.50"	2.00"	3.69"	1.56"	13.00"	21.00"	14.00"	3.50"	3.500"	4.50"	17.5"
	5.00" STD. 127.0	3.19" 80.95	16.88" 428.63	5.00" 127.0	9.31" 236.53													
	5.50" 139.7	3.19" 80.95	16.88" 428.63	5.00" 127.0	9.31" 236.53													
	7.00" 177.8	3.50" 88.9	17.19" 436.56	5.31" 134.93	9.44" 239.71													
HB 120 12.00" BORE	5.50" 139.7	3.19" 80.95	19.78" 502.4	5.44" 138.09	10.63" 269.87	14.5"	14.88"	10.00"	2.50"	4.44"	2.09"	15.50"	24.50"	16.50"	4.00"	4.000"	5.50"	20.75"
	7.00" STD. 177.8	3.50" 88.9	20.09" 510.28	5.75" 146.05	10.93" 277.81													
	8.00" 203.2	4.00" 101.6	20.59" 522.98	6.25" 158.75	11.50" 292.1													

STYLE 14
CAP
FIXED CLEVIS

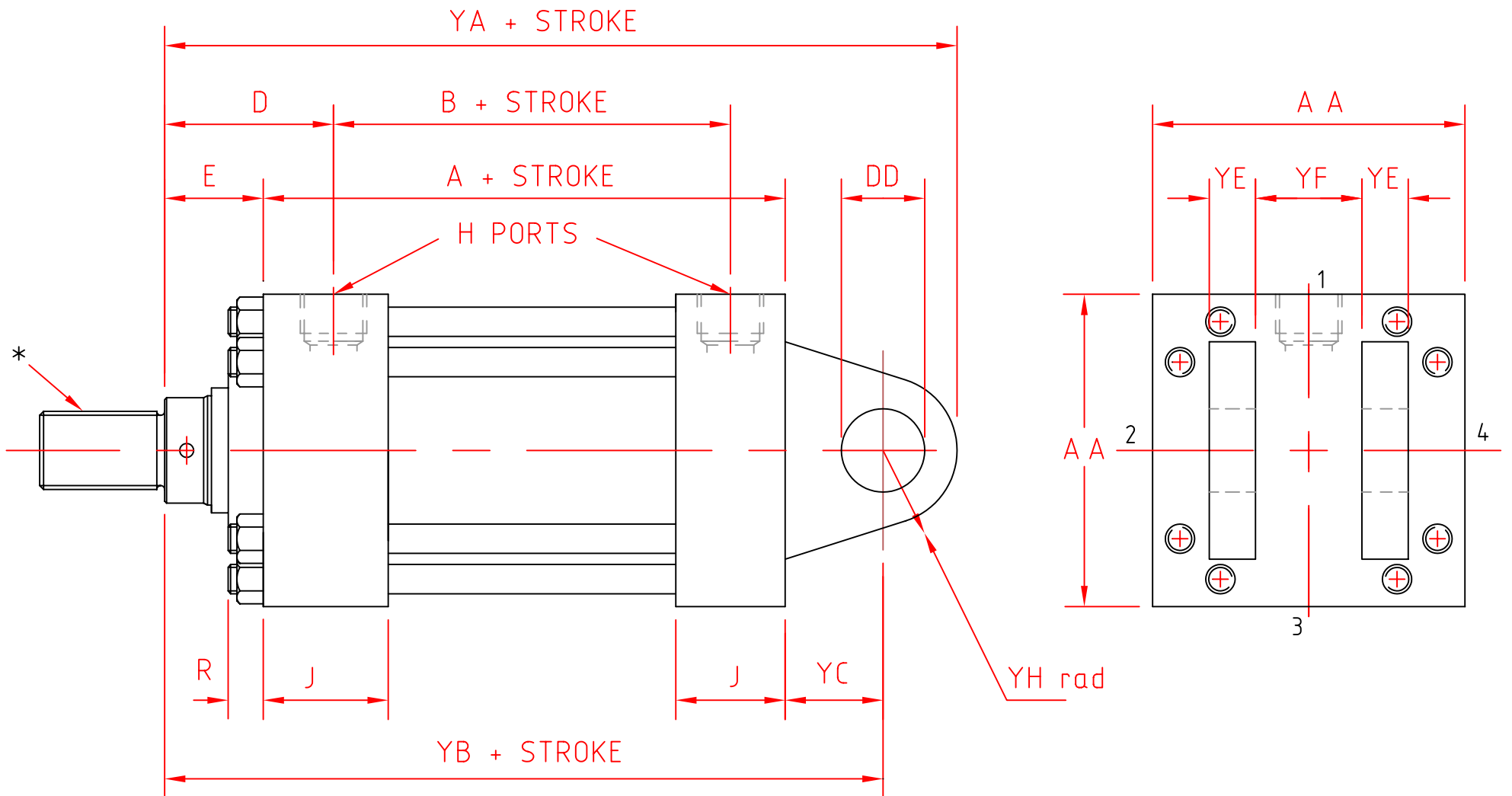

* MALE ROD END SHOWN See sheet 4A for male & female variations and dimensions

- Single Slotted CUSH. ADJ.
- Cross Slotted CUSH. Relief (Fixed)

CYLINDER SIZE	ROD DIA. E E	E	D	YA	YB	A	AA	B	H	J	R	YC	YE	YF	YH	DD Ø
HB 100 10.00" BORE	4.50" 114.3	2.94" 74.6	4.75" 120.65	22.56" 573.08	19.06" 484.18											
	5.00" STD. 127.0	3.19" 80.95	5.00" 127.0	22.81" 579.43	19.31" 490.53	12.13"	12.63"	8.50"	2.00"	3.69"	1.56"	4.00"	2.00"	4.00"	3.50"	3.500"
	5.50" 139.7	3.19" 80.95	5.00" 127.0	22.81" 579.37	19.31" 490.53	307.97	320.67	215.90	BSPP.	93.65	39.68	101.6	50.8	101.6	88.9	88.90"
	7.00" 177.8	3.50" 88.9	5.31" 134.93	23.13" 587.37	19.63" 498.47											
HB 120 12.00" BORE	5.50" 139.7	3.19" 80.95	5.44" 138.09	26.19" 665.15	22.19" 563.56											
	7.00" STD. 177.8	3.50" 88.9	5.75" 146.05	26.50" 673.10	22.50" 571.50	14.5"	14.88"	10.00"	2.50"	4.44"	2.09"	4.50"	2.25"	4.50"	4.00"	4.000"
	8.00" 203.2	4.00" 101.6	6.25" 158.75	27.00" 685.80	23.00" 584.20	368.30	377.82	254.00	SAE.	112.71	53.18	57.15	57.15	114.3	101.6	101.60

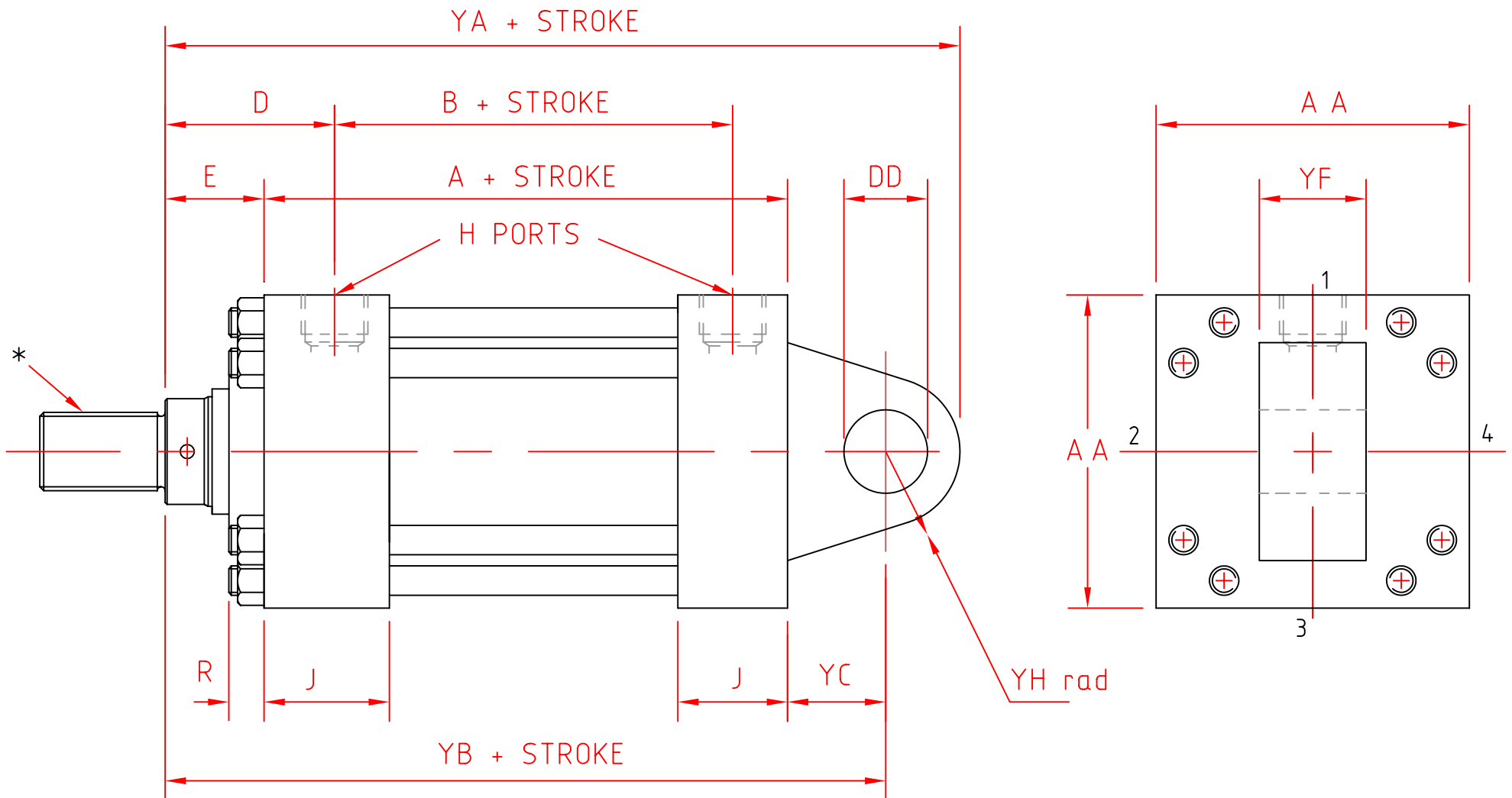

* MALE ROD END SHOWN See sheet 4A for male & female variations and dimensions

- Single Slotted CUSH. ADJ.
- Cross Slotted CUSH. Relief (Fixed)

CYLINDER SIZE	ROD DIA. E E	E	D	YA	YB	A	AA	B	H	J	R	YC	YF	YH	DD Ø
HB 100 10.00" BORE	4.50" 114.3	2.94" 74.6	4.75" 120.65	22.56" 573.08	19.06" 484.18										
	5.00" STD. 127.0	3.19" 80.95	5.00" 127.0	22.81" 579.43	19.31" 490.53	12.13"	12.63"	8.50"	2.00"	3.69"	1.56"	4.00"	4.00"	3.50"	3.500"
	5.50" 139.7	3.19" 80.95	5.00" 127.0	22.81" 579.43	19.31" 490.53	307.97	320.67	215.90	BSPP.	93.65	39.68	101.6	101.6	88.9	88.90
	7.00" 177.8	3.50" 88.9	5.31" 134.93	23.13" 587.37	19.63" 498.47										
HB 120 12.00" BORE	5.50" 139.7	3.19" 80.95	5.44" 138.09	26.19" 665.15	22.19" 563.56										
	7.00" STD. 177.8	3.50" 88.9	5.75" 146.05	26.50" 673.10	22.50" 571.50	14.5"	14.88"	10.00"	2.50"	4.44"	2.09"	4.50"	4.50"	4.00"	4.000"
	8.00" 203.2	4.00" 101.6	6.25" 158.75	27.00" 685.80	23.00" 584.20	368.30	377.82	254.00	SAE.	112.71	53.18	57.15	114.3	101.6	101.60

THEORETICAL PUSH AND PULL FORCES FOR HYDRAULIC CYLINDERS

DETERMINE FORCE REQUIRED— TO SELECT A CYLINDER FOR AN APPLICATION, FIRST DETERMINE THE MAXIMUM PUSH AND/OR PULL FORCE REQUIRED TO DO THE JOB. THEN USE THIS CHART TO SELECT THE CYLINDER THAT GIVES THE NECESSARY FORCE FOR YOUR APPLICATION. IT SHOULD BE NOTED THAT THE FORCE REQUIREMENTS DERIVED BY FORMULA ARE ONLY THEORETICALLY CORRECT. OTHER FORCES MUST BE PROVIDED FOR.

PRESSURE DROP - WHICH MEANS THAT WORKING PRESSURE AT THE CYLINDER PORT WILL BE SOMEWHAT LESS THAN SYSTEM PRESSURE - SHOULD BE ALLOWED FOR IN SUCH CALCULATIONS. A MARGIN FOR OVERCOMING FRICTION IN THE CYLINDER LIKEWISE MUST BE ADDED.

A CERTAIN AMOUNT OF THE FORCE THAT A CYLINDER CAN EXERT IS COUNTER ACTED BY THE FRICTION DEVELOPED THROUGH THE PACKING AND TO A LESSER EXTENT BY THE WEIGHT OF THE PISTON. THE AMOUNT REQUIRED TO COUNTER ACT THESE RESISTANCES HAS BEEN REDUCED IN THESE CYLINDERS TO LESS THAN 5% OF THE CYLINDERS THEORETICAL POWER.

BORE DIA.	ROD DIA.	CYL. WORK	WORK AREA SQ.IN.	WORKING PRESSURE P.S.I.					
				500	1000	1500	2000	2500	3000
1.50"		PUSH	1.77	885	1770	2655	3540	4425	5310
	0.625	PULL	1.46	730	1460	2190	2920	3650	4380
	1.00	PULL	.98	490	980	1470	1960	2450	2940
2.00"		PUSH	3.14	1570	3140	4710	6280	7850	9420
	1.00	PULL	2.36	1180	2360	3540	4720	5900	7080
	1.375	PULL	1.66	830	1660	2490	3320	4150	4980
2.50"		PUSH	4.91	2455	4910	7365	9820	12275	14730
	1.00	PULL	4.12	2060	4120	6180	8240	10300	12360
	1.375	PULL	3.42	1710	3420	5130	6840	8550	10260
3.25"		PUSH	8.30	4150	8300	12450	16600	20750	24900
	1.375	PULL	6.81	3405	6810	10215	13620	17025	20430
	1.75	PULL	5.89	2945	5890	8835	11780	14725	17670
4.00"		PUSH	12.57	6285	12570	18855	25140	31425	37710
	1.75	PULL	10.16	5080	10160	15240	20320	25400	30480
	2.00	PULL	9.42	4710	9420	14130	18840	23550	28260
5.00"		PUSH	19.64	9820	19640	29460	39280	49100	58920
	2.00	PULL	16.49	8245	16490	24735	32980	41225	49470
	2.50	PULL	14.73	7365	14730	22095	29460	36825	44190
6.00"		PUSH	28.27	14135	28270	42405	56540	70675	84810
	2.50	PULL	23.37	11685	23370	35055	46740	58425	70110
	3.00	PULL	21.21	10605	21210	31815	42420	53025	63630
7.00"		PUSH	38.48	19240	38480	57720	76960	96200	115440
	3.00	PULL	31.42	15710	31420	47130	62840	78550	94260
	3.50	PULL	28.86	14430	28860	43290	57720	72150	86580
8.00"		PUSH	50.27	25135	50270	75405	100540	125675	150810
	3.50	PULL	40.64	20320	40640	60960	81280	101600	121920
	4.00	PULL	37.70	18850	37700	56550	75400	94250	113100
10.00"		PUSH	78.54	39270	78540	117810	157080	196350	235620
	4.50	PULL	62.64	31320	62640	93960	125280	156600	187920
	5.00	PULL	58.91	29455	58910	88365	117820	147275	176730
12.00"		PUSH	113.10	56550	113100	169650	226200	282750	339300
	4.50	PULL	97.19	48595	97190	145785	194380	242975	291570
	5.00	PULL	93.46	46730	93460	140190	186920	233650	280380
	5.50	PULL	89.34	44670	89340	134010	178680	223350	268020
	7.00	PULL	74.61	37305	74610	111915	149220	186525	223830

BASIC HYDRAULIC CYLINDER FORMULA

THE CYLINDER OUTPUT FORCES ARE DERIVED FROM THE FORMULA.

$$F = P \times A$$

- WHERE
- F = FORCE IN POUNDS
 - P = PRESSURE AT THE CYLINDER IN POUNDS PER SQUARE INCH
 - A = EFFECTIVE AREA OF CYLINDER PISTON IN SQUARE INCHES

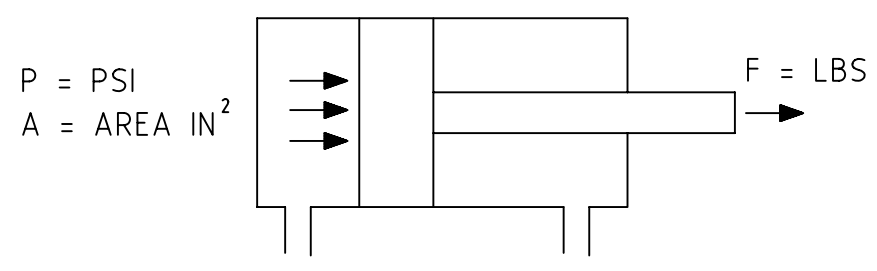

STOP TUBE AND PISTON ROD STROKE SELECTION

THE STOP TUBE IS A GENERALLY ACCEPTED AND PREFERRED METHOD OF REDUCING PISTON AND BEARING LOADS ON LONG PUSH STROKE CYLINDERS. IT MINIMIZES THE JACK-KNIFE EFFECT AND REDUCES BEARING PRESSURE.

AS ILLUSTRATED BELOW THE STOP TUBE IS PLACED BETWEEN THE PISTON AND THE CYLINDER GLAND TO RESTRICT THE EXTENDED POSITION OF THE ROD SO THAT THE LENGTHENED SPACE BETWEEN THE PISTON AND GLAND PROVIDES ADDITIONAL STRENGTH AND SIDE SUPPORT FOR THE EXTENDED ROD

STOP TUBES ARE NORMALLY USED FOR STROKES EXCEEDING 40 INCHES OR MORE. THE BASIC LENGTH OF THE CYLINDER IS INCREASED BY THE STOP TUBE LENGTH.

$$\text{STOP TUBE LENGTH (INCH)} = \frac{\text{STROKE (INCH)} - 40 (\text{INCH})}{10}$$

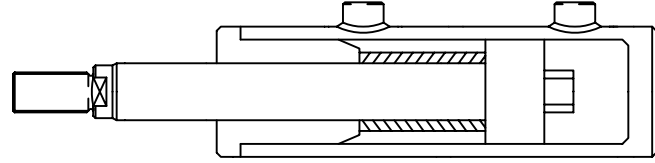

THE PISTON ROD IN A CYLINDER ACTS AS A COLUMN UNDER THRUST (PUSH) CONDITIONS. IT IS, THEREFORE, SUBJECTED TO BOTH COMPRESSIVE STRESSES AND BUCKLING STRESSES. CONSEQUENTLY, IT MAY BE NECESSARY TO INCREASE THE ROD DIAMETER TO ACHIEVE THE NECESSARY COLUMN "STRENGTH".

THE VALUE OF "K" SHOWN IN THE TABLES ARE OUR RECOMMENDED MAXIMUM EQUIVALENT "K" LENGTH FOR NORMAL HORIZONTAL AND VERTICAL APPLICATIONS UNDER LIGHT TO MEDIUM SHOCK LOADS. FOR HEAVY DUTY SHOCK LOADING AND HIGH CYCLING, CHOOSE THE NEXT ROD SIZE LARGER THAN SHOWN BY THE TABLE.

PROCEDURE

1. DETERMINE ACTUAL LENGTH "L" FROM THE APPLICABLE DIAGRAM REMEMBERING TO ADD IN STOP TUBE AND ANY ADDITIONAL ROD EXTENSION
2. CALCULATE "K" FROM FORMULA ADJACENT TO EACH DIAGRAM GROUP.
3. DETERMINE CYLINDER THRUST FROM APPLICABLE FORMULA.
4. FIND ROD SIZE FROM TABLE BY READING ACROSS LINE FROM THE PUSH (LOAD) FIGURE UNTIL THE FIRST FIGURE EXCEEDING CALCULATED "K" IS REACHED. RECOMMENDED ROD DIAMETER IS THEN READ FROM THE TOP OF THE TABLE.
5. IF PISTON ROD EXCEEDS MAXIMUM ROD SIZE AVAILABLE IN CYLINDER BORE, THEN USE LARGER BORE CYLINDER AT REDUCED PRESSURE

MILLIMETRE TABLE OF "K"

PUSH kN	ROD DIAMETER															
	16	25	35	44	51	64	76	89	102	114	127	140	152	178		
1	1300															
2	920	2300														
2.5	820	2050	3920													
3	750	1870	3540													
4	650	1620	3070	5000	6450											
5	580	1450	2740	4500	5800											
6	530	1320	2500	4100	5300											
8	460	1140	2160	3500	4600	7100										
10	410	1020	1930	3150	4100	6400										
12	380	940	1760	2900	3750	5850										
14	350	870	1630	2670	3450	5400										
18	310	770	1440	2350	3050	4750	6870									
22	280	690	1300	2130	2750	4300	6200	8500								
26		640	1190	1950	2550	3950	5700	7850								
30		590	1120	1820	2350	3700	5300	7300								
35		550	1020	1680	2200	3400	4900	6700	8800							
40		510	960	1570	2050	3200	4600	6300	8200							
45		480	910	1480	1930	3000	4350	5900	7700	9700	12100					
50		460	860	1400	1830	2850	4100	5600	7320	9250	11200					
60			790	1280	1670	2600	3750	5100	6650	8400	10200					
80			680	1120	1450	2250	3250	4420	5790	7300	9100	11000				
100			610	990	1300	2000	2900	4000	5150	6550	8100	10000	11800	15800		
150				810	1060	1630	2360	3230	4200	5300	6610	8100	9650	12800		
200					910	1420	2050	2800	3660	4600	5750	7000	8350	11200		
250						1260	1820	2500	3250	4120	5150	6250	7450	10000		
300							1660	2280	2950	3760	4700	5700	6800	9100		
350							1540	2100	2760	3500	4350	5300	6300	8400		
400							1440	1970	2600	3260	4080	4930	5650	7800		
500								1750	2310	2920	3620	4400	5250	7000		
750									1880	2370	2970	3600	4250	5650		
1000										2050	2570	3110	3700	4880		
1250											2310	2790	3300	4370		
1500												2200	2550	3020	4000	
1750													2350	2800	3700	
2000														2600	3450	

THIS AREA OVER
MAX. THRUST ABILITY
OF PISTON ROD

INCH TABLE OF "K"

PUSH lb.f	ROD DIAMETER																
	5/8	1	1 3/8	1 3/4	2	2 1/2	3	3 1/2	4	4 1/2	5	5 1/2	6	7			
200	54																
500	34	86	165														
600	31	78	150														
800	27	67	129	207	270												
1000	24	60	115	185	241												
1200	22	55	105	170	221												
1400	20	51	97	156	205												
1600	19	48	90	146	192												
1800	18	45	85	138	181	280											
2000	17	43	80	131	171	267											
2500	15	38	72	117	153	238											
3000	14	35	65	107	140	218											
4000	12	30	57	93	121	189	272										
5000	11	27	50	83	108	172	243	330									
6000		25	46	76	99	154	221	301									
7000		23	42	70	91	143	205	280									
8000		21	39	66	85	134	192	262	342								
9000		20	37	62	80	126	181	246	323								
10000		19	35	59	76	119	171	234	307	386							
12000		17	32	54	70	109	156	212	279	351	435						
16000			27	47	60	94	135	184	241	305	375						
20000			24	42	54	84	122	165	216	272	336	405					
30000				34	44	69	99	134	176	222	274	330	390				
40000				29	38	60	86	116	152	193	238	286	337				
50000					34	54	77	103	136	172	212	256	300	405			
60000						49	70	94	124	157	193	233	250	370			
80000							61	82	107	136	167	202	278	320			
100000								55	73	96	122	150	181	228	285		
125000									66	86	109	134	162	192	255		
150000										60	78	99	123	148	175	234	
200000											68	86	106	127	152	202	
250000												77	94	114	146	180	
300000													86	104	124	165	
350000														96	115	152	
400000															90	107	142

THIS AREA OVER
MAX. THRUST ABILITY
OF PISTON ROD

PISTON ROD BUCKLING LOAD EXAMPLES

INSTALLATION SITUATION OF CYLINDERS

FREE BUCKLING LENGTH (K)

SITUATION 1
BOTH ENDS PIVOTED AND GUIDED (ROUND)

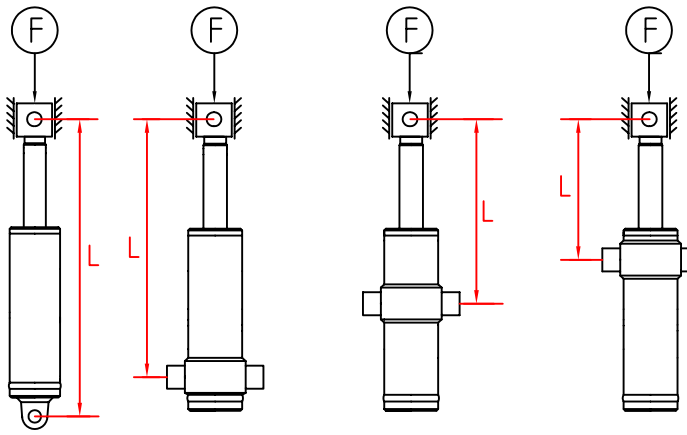

$$K = L$$

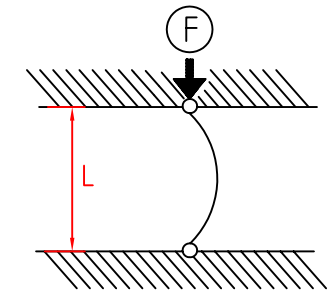

SITUATION 2
ONE END FIXED AND ONE END FREE.

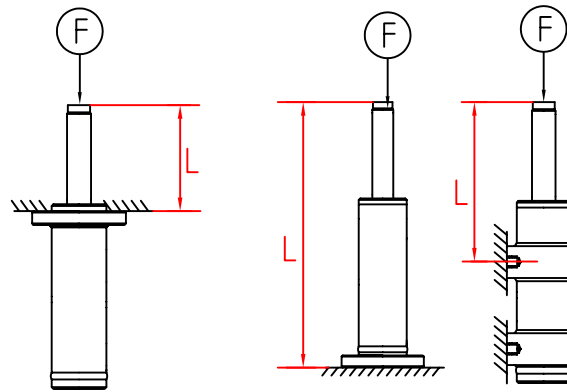

$$K = 2L$$

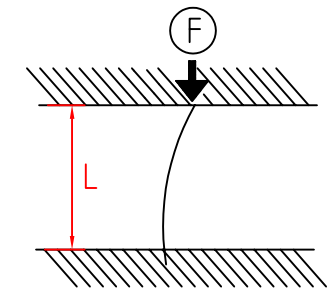

SITUATION 3
ONE END GUIDED AND PIVOTED AND ONE END FIXED

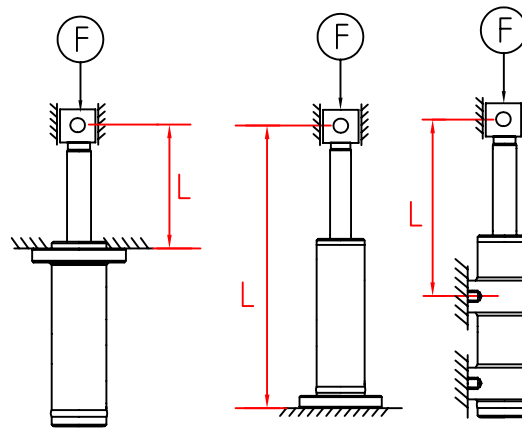

$$K = L \times \sqrt{\frac{1}{2}}$$

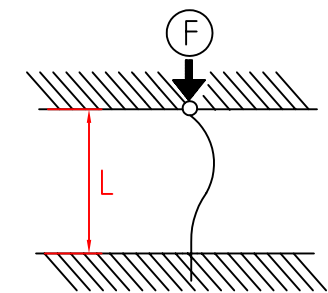

SITUATION 4
BOTH ENDS FIXED AND GUIDED

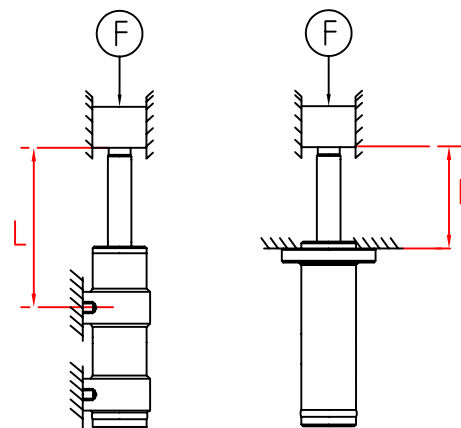

$$K = \frac{L}{2}$$

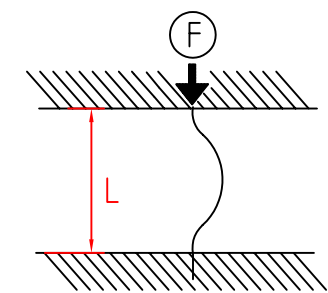

HYDRAULIC CYLINDER GENERAL INFORMATION

GENERAL
INFORMATION

HANDLING OF HYDRAULIC CYLINDERS

- CARE SHOULD BE TAKEN AT ALL TIMES TO PREVENT DAMAGE TO CYLINDER OR INJURY TO PERSONNEL.
- WHENEVER POSSIBLE MAKE SURE THAT THE CYLINDER IS IN FULLY RETRACTED POSITION AND THAT THE PISTON IS RESTRAINED FROM EXTENDING BY GRAVITY OR OTHER MEANS.
- AVOID THE USE OF CHAINS WRAPPED AROUND THE CYLINDER AS THESE CAN SLIP AND CAUSE CONSIDERABLE DAMAGE, ESPECIALLY TO THE PISTON ROD.

STORAGE OF HYDRAULIC CYLINDERS

WHEN STORAGE PERIODS ARE REQUIRED THE FOLLOWING PROCEDURES ARE RECOMMENDED :

- THE CYLINDER MUST BE STORED INDOORS IN A DRY AND NON-CORROSIVE ENVIRONMENT.
- PROTECTION PLUGS FITTED TO PORTS MUST BE LEFT ON AT ALL TIMES.
- PROTECT THE CYLINDER FROM INTERNAL CORROSION AND EXTERNAL CORROSION. IT IS RECOMMENDED THE CYLINDER BE FILLED WITH OPERATING FLUID.
- STORAGE IN A VERTICAL POSITION IS RECOMMENDED WITH THE PISTON ROD FACING UPWARDS. THIS WILL MINIMIZE STATIC SIDE LOADS ON THE SEALS AND CORROSION DUE TO POSSIBLE CONDENSATION IF THE CYLINDER IS NOT FILLED.
- IF VERTICAL STORAGE IS NOT POSSIBLE THEN THE CYLINDER CAN BE STORED HORIZONTALLY. HOWEVER FOR LONG PERIODS OF STORAGE THE CYLINDER MUST BE FILLED WITH THE WORKING FLUID AND ROTATION OF THE CYLINDER ON A FORTNIGHTLY BASIS IS RECOMMENDED.

IDENTIFICATION

- IN ALL CASES IDENTIFICATION OF THE CYLINDER IS STAMPED ON THE FRONT END, AS ILLUSTRATED. IN THE CASE THE CYLINDER IS SPECIAL THE IDENTIFICATION IS THE DRAWING NUMBER (H/L00####).

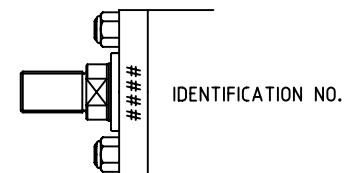

CYLINDER INSTALLATION

- ALL CYLINDERS ARE INDIVIDUALLY TESTED BEFORE SHIPMENT TO ASSURE FREEDOM FROM DEFECTS. IT IS RECOMMENDED THAT THE SHIPPING PLUGS IN THE CYLINDER PORTS NOT BE REMOVED DURING INSTALLATION UNTIL ACTUAL PIPING CONNECTIONS ARE TO BE MADE.

CYLINDER MOUNTING

- ALIGN THE CYLINDER CAREFULLY KEEPING MOUNTING SURFACES SQUARE, PARALLEL, CONCENTRIC AND TRUE (AS APPLICABLE) WITH THE WORK DIRECTION.
- TRUNNION AND PIVOT MOUNTED CYLINDERS SWIVEL IN ONE DIRECTION ONLY WITH TRUNNION PINS AND PIVOT PINS DESIGNED TO CARRY SHEAR LOADS ONLY. TRUNNION AND PIVOT BEARINGS MUST FIT CLOSELY FOR THE ENTIRE LENGTH OF THE PIN WITH TRUNNION BEARINGS HELD RIGIDLY AND IN ACCURATE ALIGNMENT.
- FLUSH MOUNTED CYLINDERS (TAPPED & LUG MOUNT) SHOULD BE PINNED OR KEYED TO PREVENT SHIFTING FROM LOAD APPLICATION.
- PIPE CONNECTIONS : ALL CONNECTING PIPES ENDS SHOULD BE DE-BURRED AND INSIDE SHOULD BE CLEANED OF SCALE, RUST AND DIRT. REMOVE SHIPPING PLUGS AND MAKE PROPER PIPE CONNECTION.
- CYLINDER OPERATION : OPERATE THE CYLINDER SEVERAL TIMES TO MAKE SURE IT IS FUNCTIONING PROPERLY. CHECK FOR LEAKS.

CUSHION ADJUSTMENT

- CUSHIONED CYLINDERS ARE ADJUSTED AND TESTED AT THE FACTORY, BUT MAY REQUIRE ADDITIONAL ADJUSTMENT AFTER CONNECTION TO THE WORK LOAD. TO INCREASE THE EFFECTIVENESS OF THE CUSHIONS TURN THE ADJUSTING SCREWS CLOCKWISE TO OBTAIN DESIRED CUSHIONING ACTION. TO DECREASE CUSHIONING ACTION, TURN THE ADJUSTING SCREW COUNTER-CLOCKWISE.

NOTE : IF INSTALLATION IS COMPLETE AND CYLINDER DOES NOT FUNCTION PROPERLY, CHECK THE FOLLOWING.

- (1) POOR ADJUSTMENT OF THE CYLINDER WITH ITS MATING PIECES.
- (2) INSUFFICIENT PRESSURE OR LEAKAGE.

CUSHION ADJUSTMENT

- CLEAN FLUID IS ESSENTIAL TO PROLONG THE SATISFACTORY OPERATION OF HYDRAULIC EQUIPMENT. KEEP OIL TANKS COVERED AND PROVIDE AN ADEQUATE FILTER.
- WITH A VERY MINOR AMOUNT OF ATTENTION AND UNDER ORDINARY CONDITIONS HYDROIL CYLINDER WILL EFFICIENTLY OPERATE FOR AT LEAST AS LONG A PERIOD AS IS GENERALLY REQUIRED OF THE EQUIPMENT OF WHICH IT IS A PART.
- SEAL REPLACEMENTS MAY BE REQUIRED AT INTERVALS ACCORDING TO THE MANNER IN WHICH THEY ARE USED.